

MEI Symposium 25

Opening Plenary

Cool learnings: How LNG fundamentals are advancing the new energy technologies of liquid H₂ and CO₂ transport



Prof.
Eric May

FTSE, FICHEM, GAICD

Managing Director
Future Energy Exports CRC

Director
Gas Capture Technologies

Melbourne
Energy
Institute



THE UNIVERSITY OF
MELBOURNE

Cool Learnings: how LNG fundamentals are advancing the new energy technologies of liquid H₂ & CO₂ transport

Professor Eric F. May

Opening Plenary – MEI Symposium 2025

5 December 2025

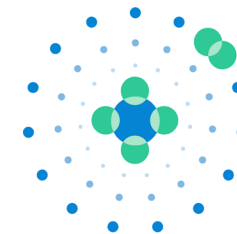

**FUTURE
ENERGY
EXPORTS**
Cooperative Research Centre

Transporting Decarbonized Energy Long Distances

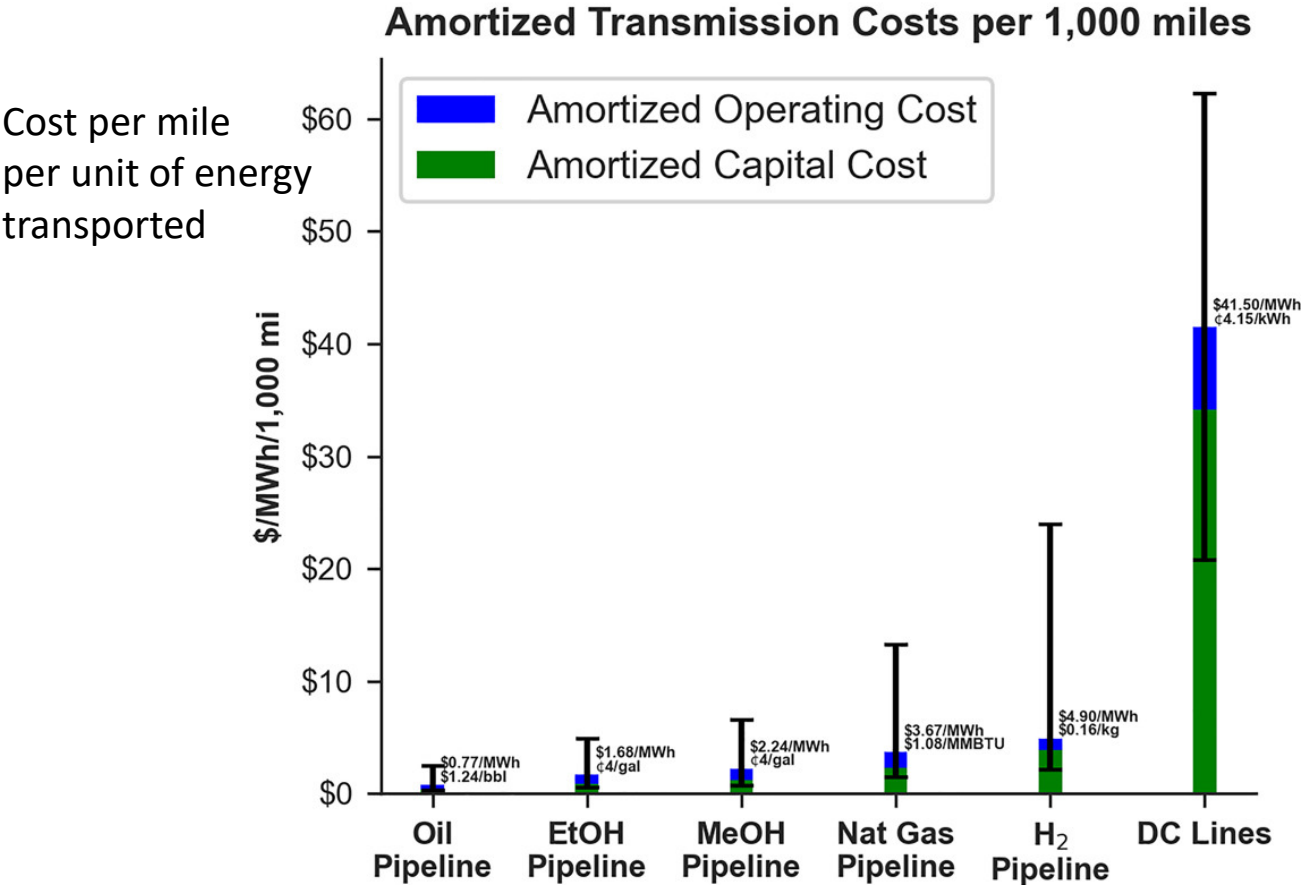

Rule of thumb:
Moving molecules is generally much cheaper than moving electrons

DeSantis et al. (2024) 10.1016/j.isci.2021.103495

Pipelines critical for producing & distributing energy

Source: US Dept of Transportation

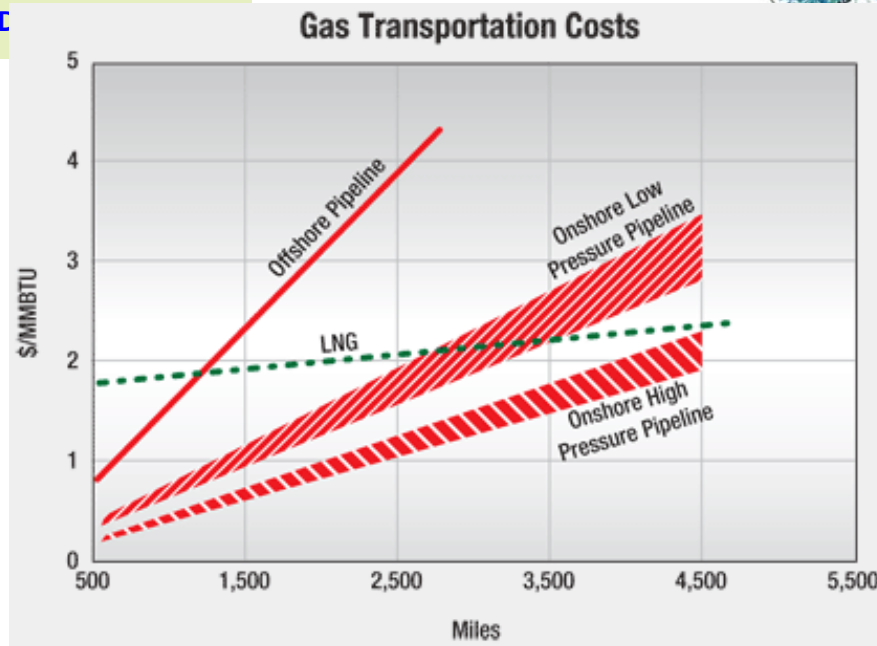
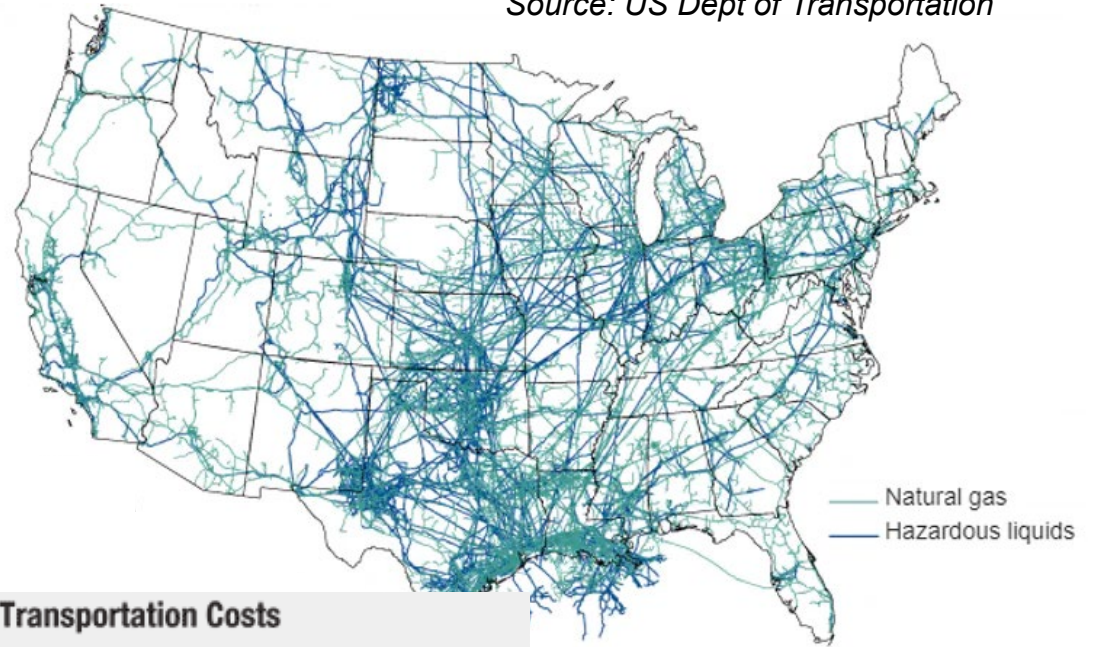
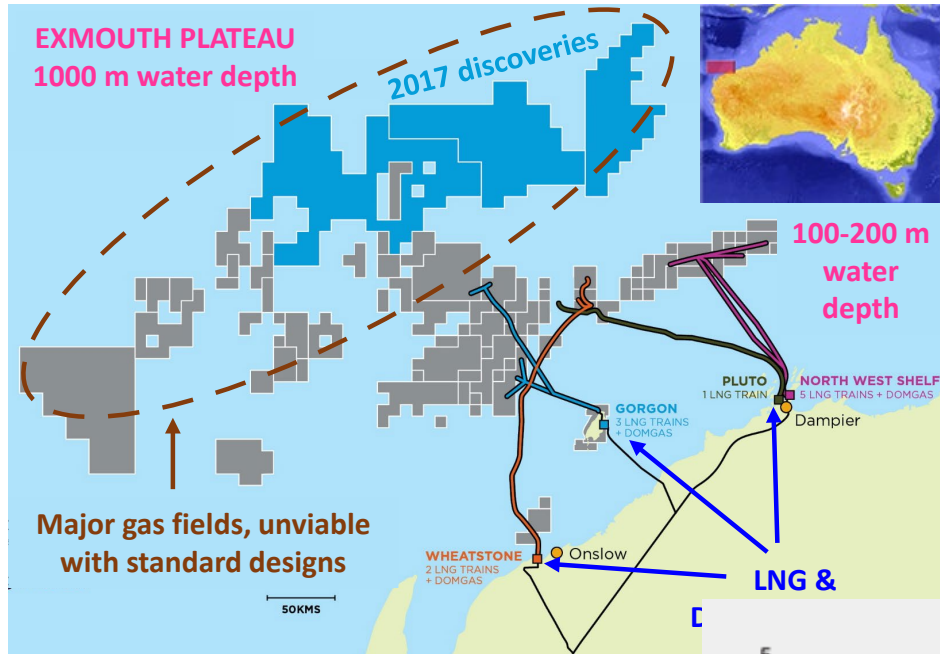

But gas pipelines across oceans are more expensive than shipping liquefied natural gas (LNG)

Lansetti (2016)
10.17238/issn2221-2698.2016.25.5

Liquefied Natural Gas (LNG) essential to global energy trade

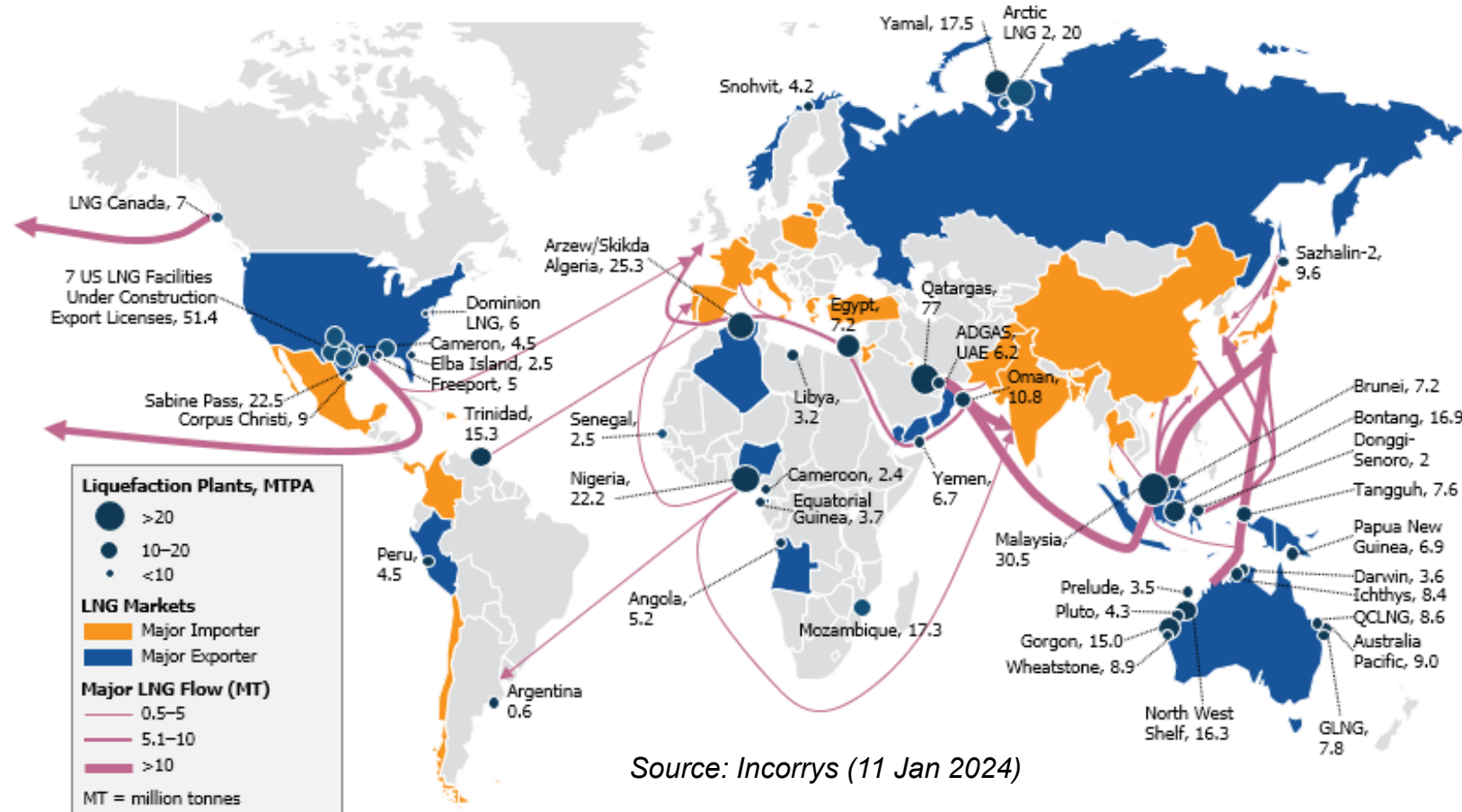

Source: Incoirys (11 Jan 2024)

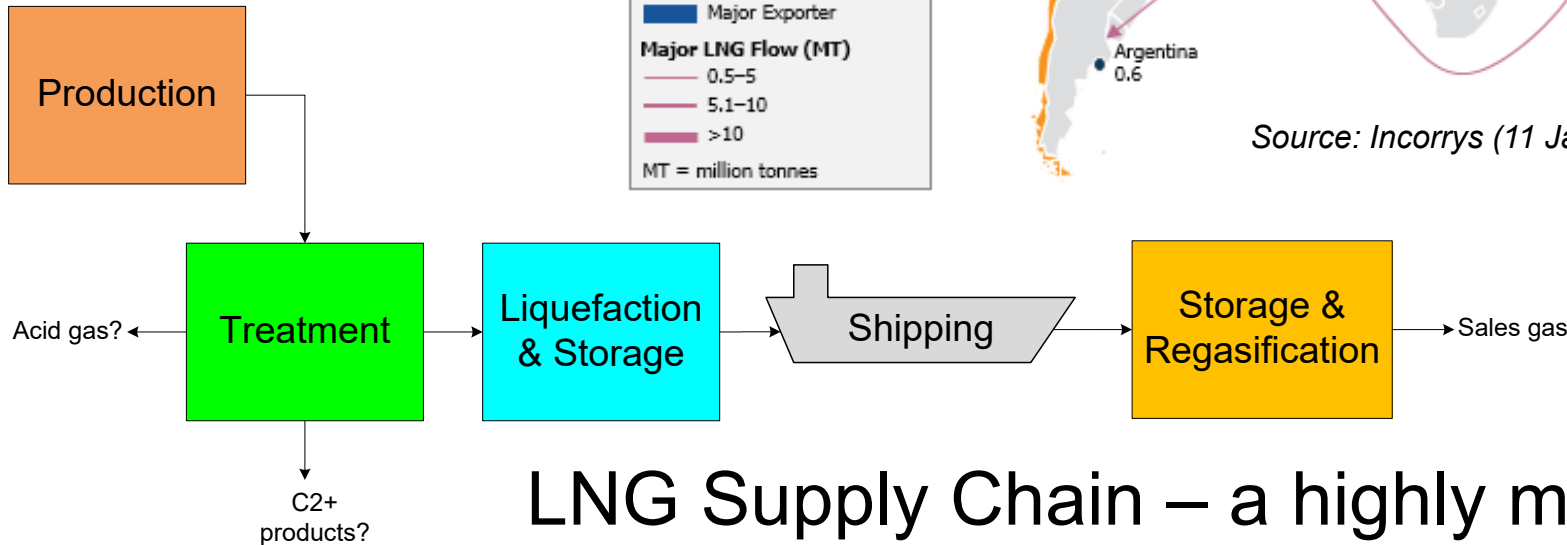

LNG Supply Chain – a highly mature set of technologies

Cool Learnings: LNG's relevance to decarbonized energy

Which molecules will be moved in a decarbonised energy system?

Rule of thumb:

Moving molecules is generally much cheaper than moving electrons

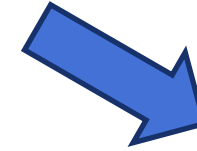
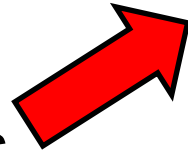

H₂ & CO₂ are highly likely candidates

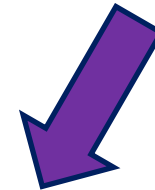

Both can be transported efficiently as cryogenic liquids

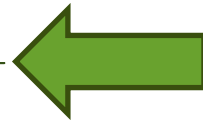

- Apply lessons learnt from LNG industry about efficient transport
- Identify differences for H₂ & CO₂ from LNG that need new knowledge

Why CO₂? All paths to Net Zero require CCS!

From Net Zero Australia Study: www.netzeroaustralia.org.au

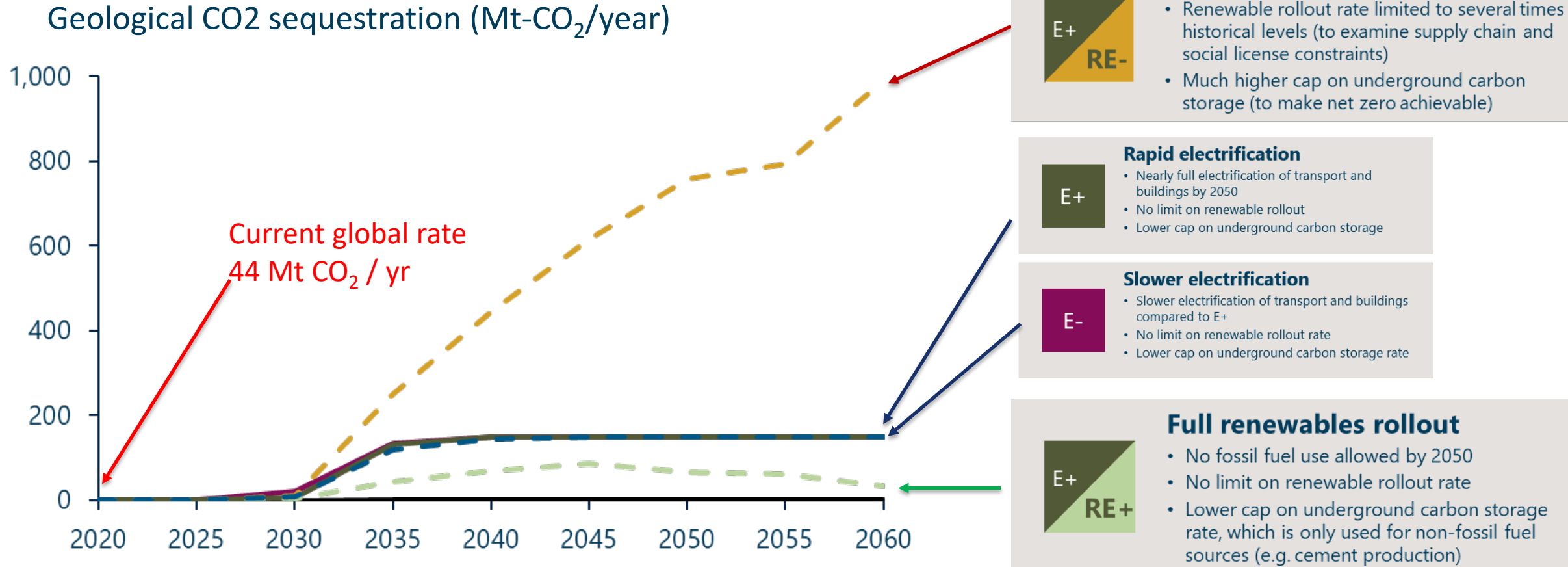

Massive economic opportunity for countries with storage options
IF CO₂ transport challenge can be solved

Closed Carbon Cycles Need Liquid CO₂ Shipping

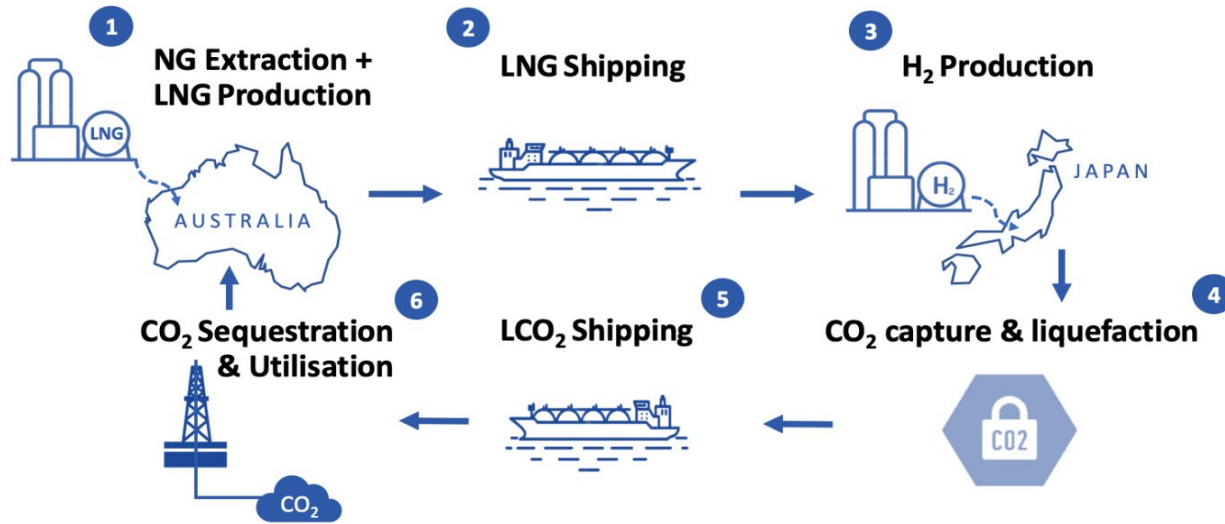

For long distances across oceans, shipping liquid CO₂ is also cheaper than pipeline transport

Current industry standard “Medium Pressure” (20 bar) regime limits CO₂ volume on ship

“Low Pressure” (8 bar) regime enables over 10,000 m³ but condition close to freezing line

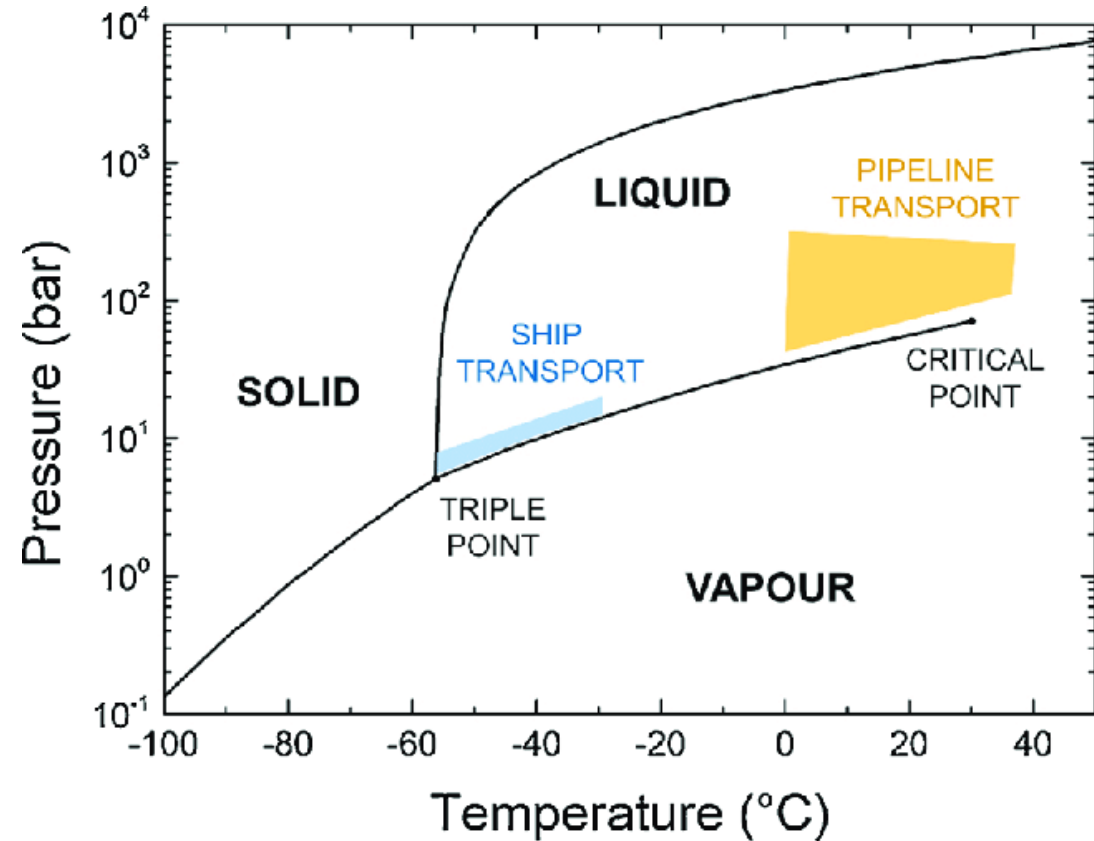

Projected sources of CO₂ for CCS: impact of impurities

	Unit	HIGH PURITY CO2	LOWER PURITY CO2
Carbon Dioxide	mol%	99.7	95.85
Water	ppm	10	50
Hydrogen Sulphide	ppm	5	5
Carbon Monoxide	mol%	0.0	0.10
SO2	ppm	20	20
Oxygen	ppm	10	10
Hydrogen	mol%	0.0	0.75
Ammonia	ppm	10	10
Methanol	ppm	10	300
Ethanol	ppm	10	200
Nitrogen	mol%	0.1	2.00
Methane	mol%	0.1	1.25

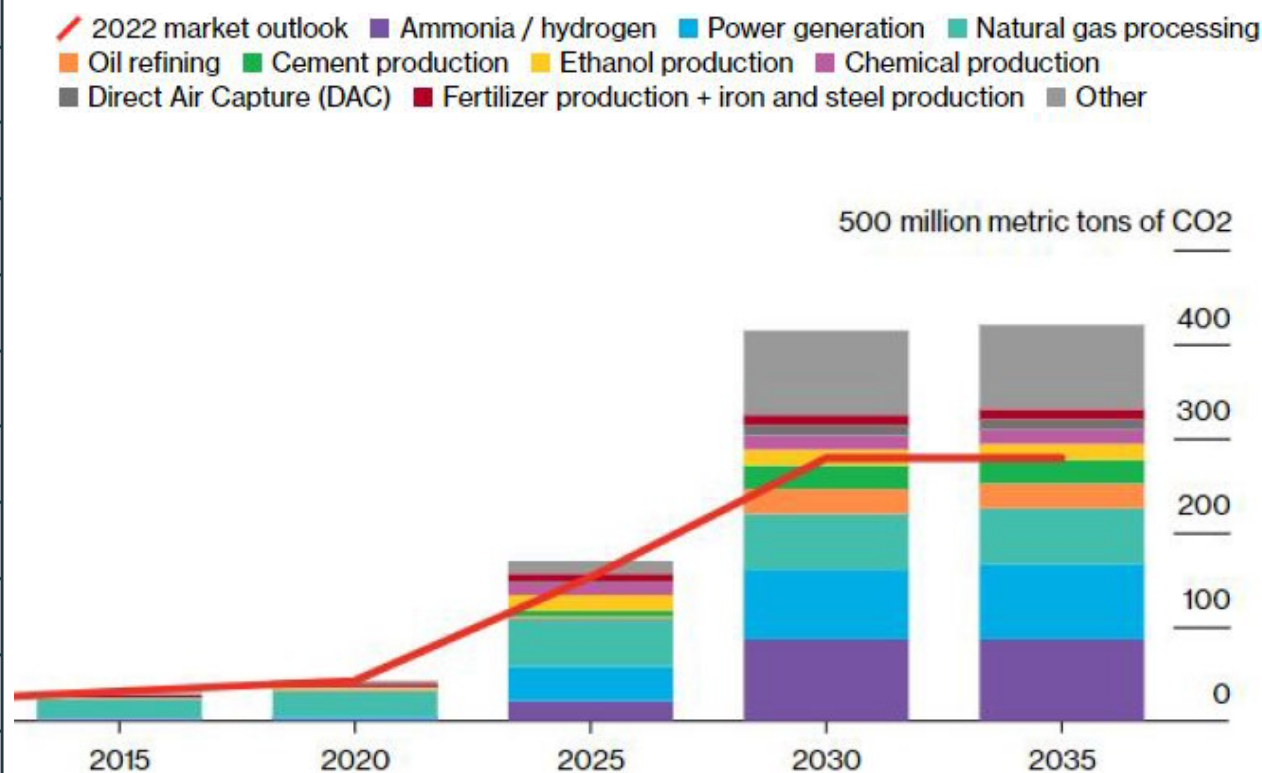

Source: BloombergNEF

BloombergNEF

■ Natural gas processing source 70% in 2022, <25% in 2030
■ Power gen., ammonia / H₂ sources dominate at 2030

Impact of impurities on CO₂ transport

	Unit	HIGH PURITY CO2	LOWER PURITY CO2
Carbon Dioxide	mol%	99.7	95.85
Water	ppm	10	50
Hydrogen Sulphide	ppm	5	5
Carbon Monoxide	mol%	0.0	0.10
SO2	ppm	20	20
Oxygen	ppm	10	10
Hydrogen	mol%	0.0	0.75
Ammonia	ppm	10	10
Methanol	ppm	10	300
Ethanol	ppm	10	200
Nitrogen	mol%	0.1	2.00
Methane	mol%	0.1	1.25

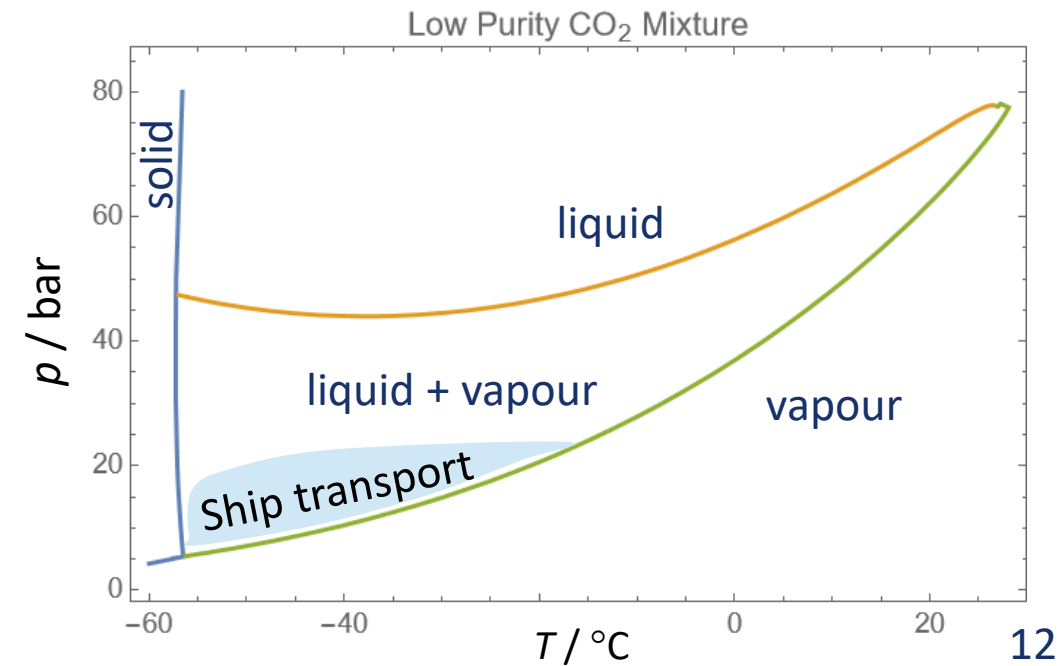
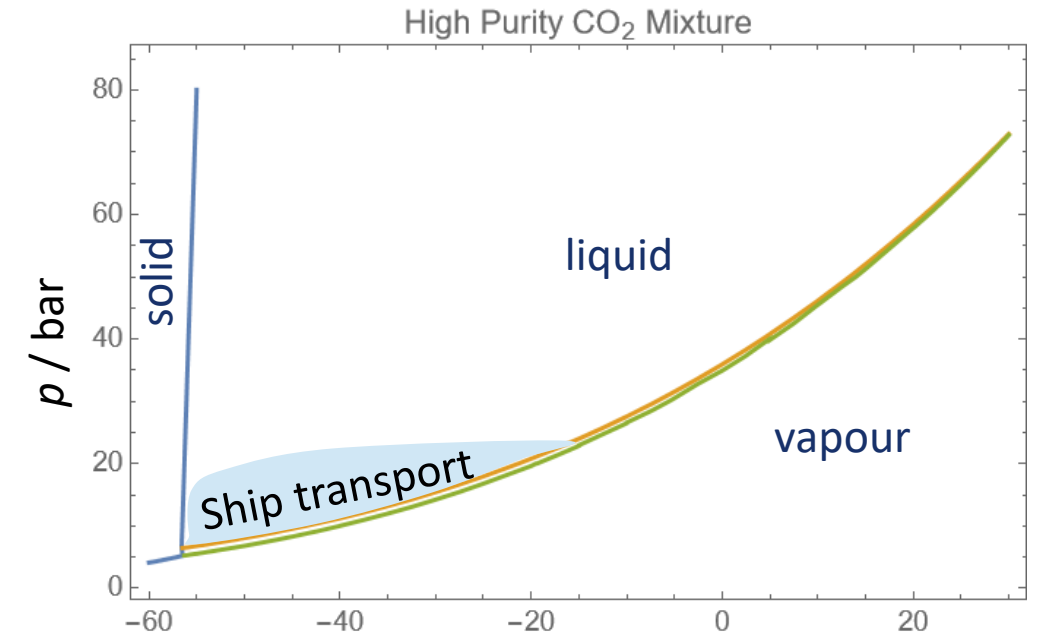

Challenges of Shipping Cryogenic Liquids: Boil Off Gas (BOG)

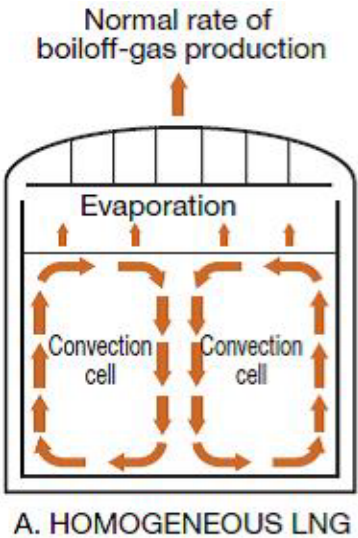

How big should the on-board BOG compressors be?
Over-design expensive

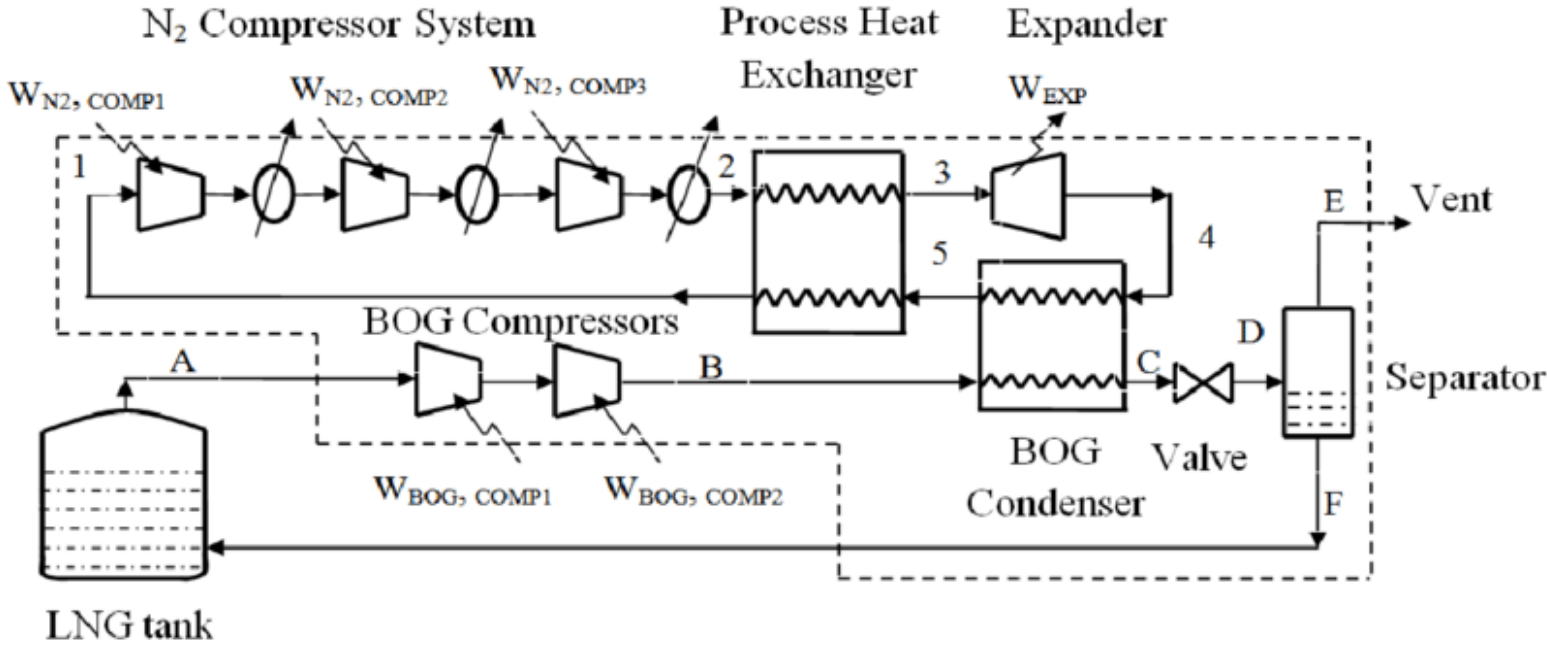

BOG rate estimates in large tanks are *empirical* – charts provided by vendor

Complex scale-dependent process: hard to model or measure accurately

Boil Off Gas Research Facilities

Experiments & models developed for LNG BOG studies

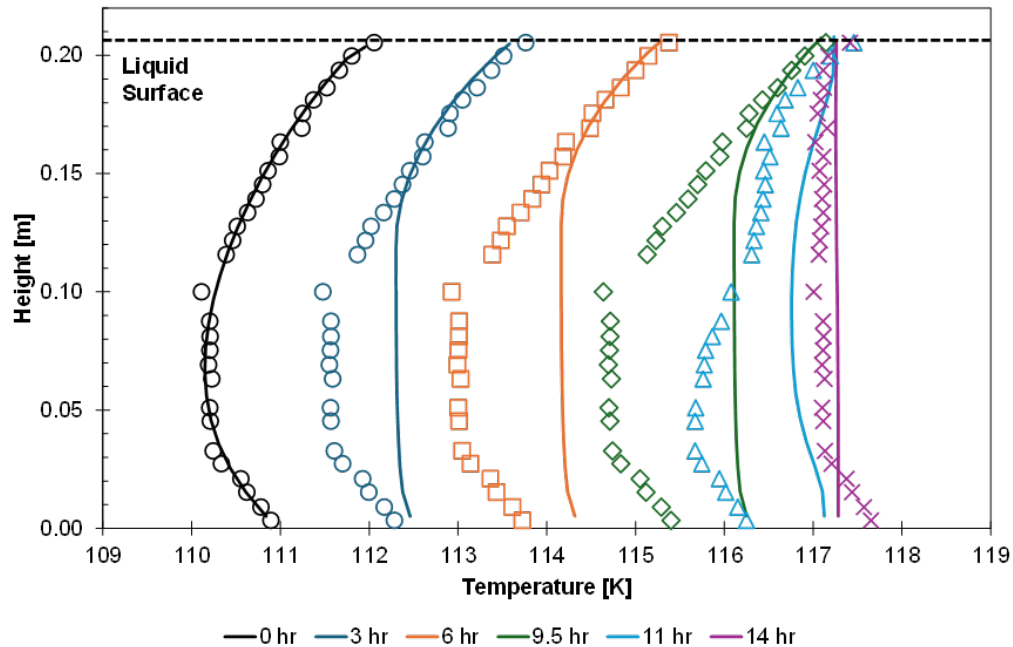
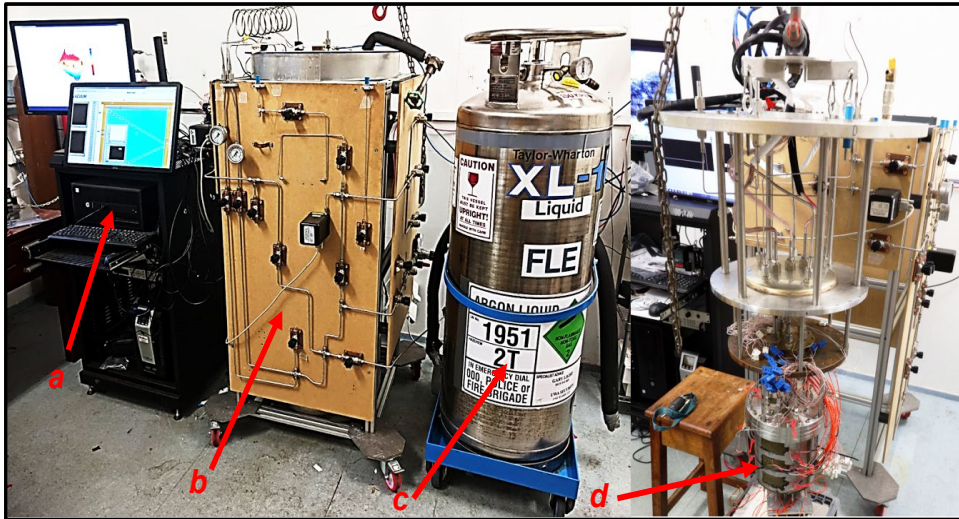

Now being applied to improve liquid CO₂ Boil-Off predictions

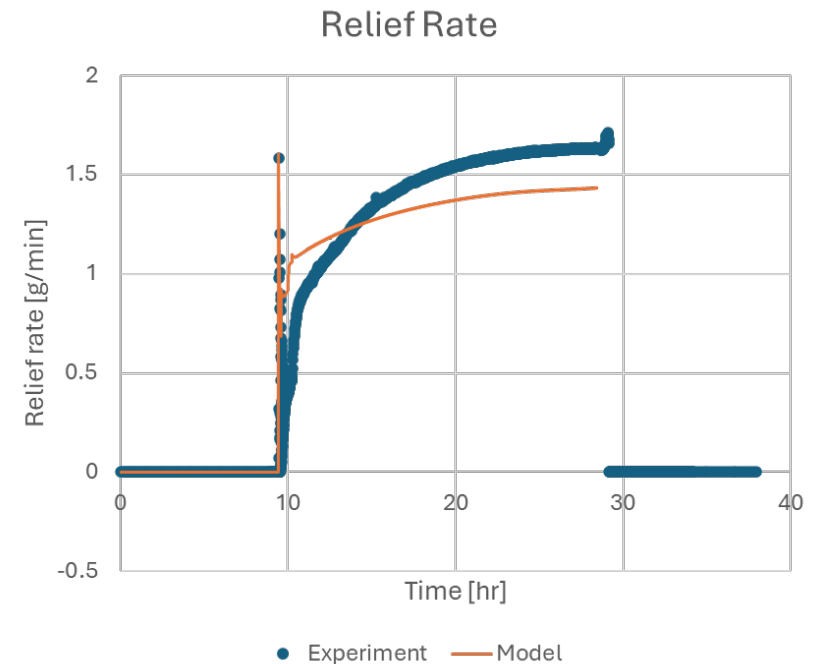
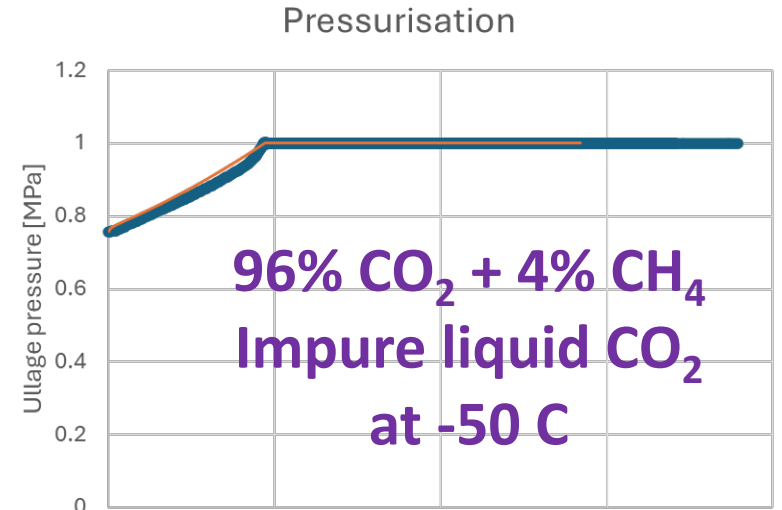

Hydrogen Value Chain For Energy Decarbonisation

Making & moving H₂ molecules also central to decarbonisation

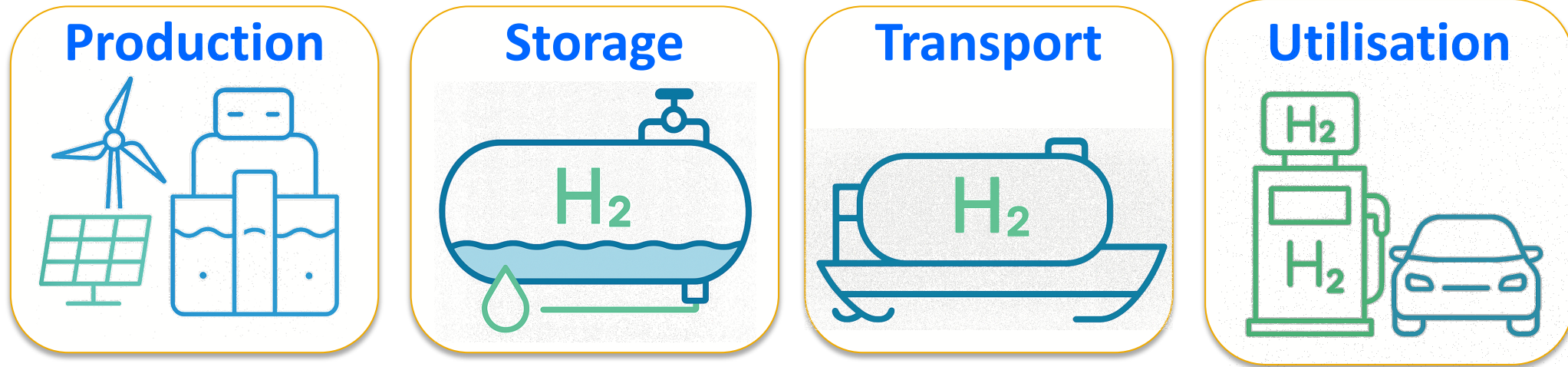

Production

Highly analogous to LNG supply chain

What lessons from LNG sector are relevant to future H₂ supply chain?

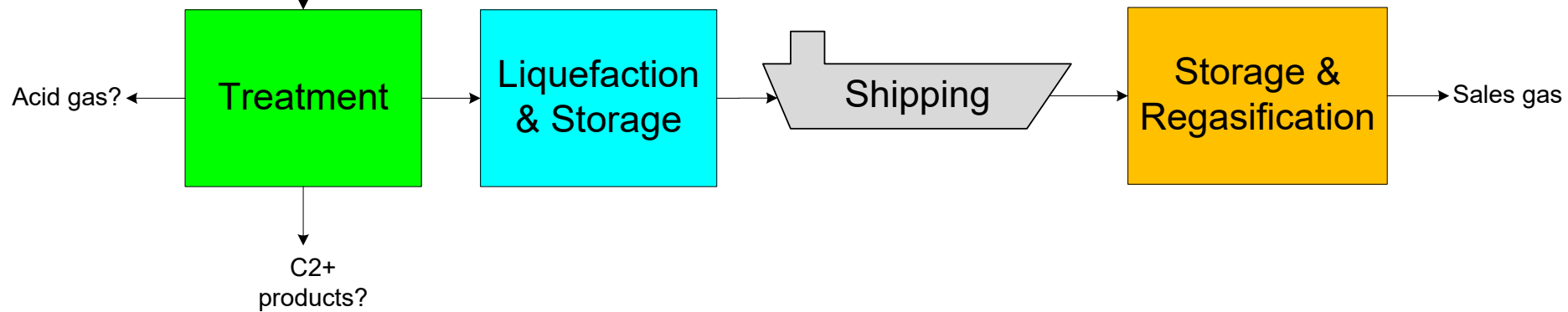

Risks Associated with Cryogenic Liquefaction

Must cool gas to -160 C
(110 K) to make LNG

Mature technology – what
could go wrong?

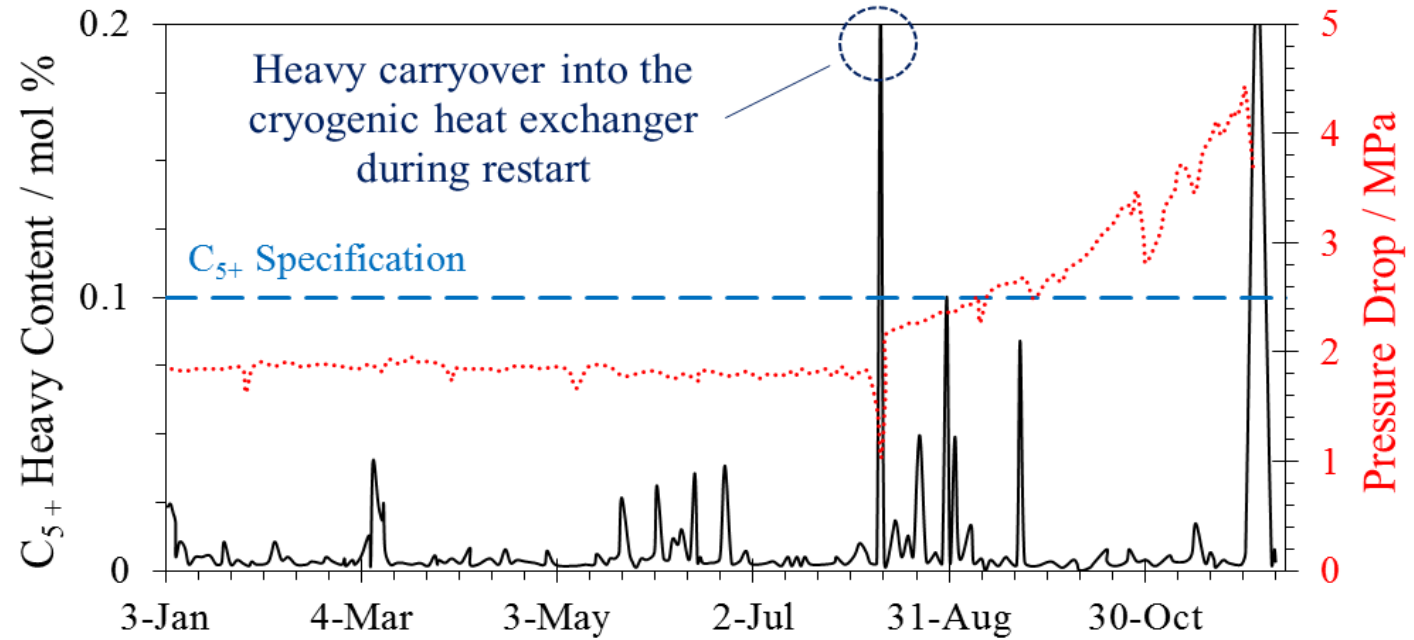
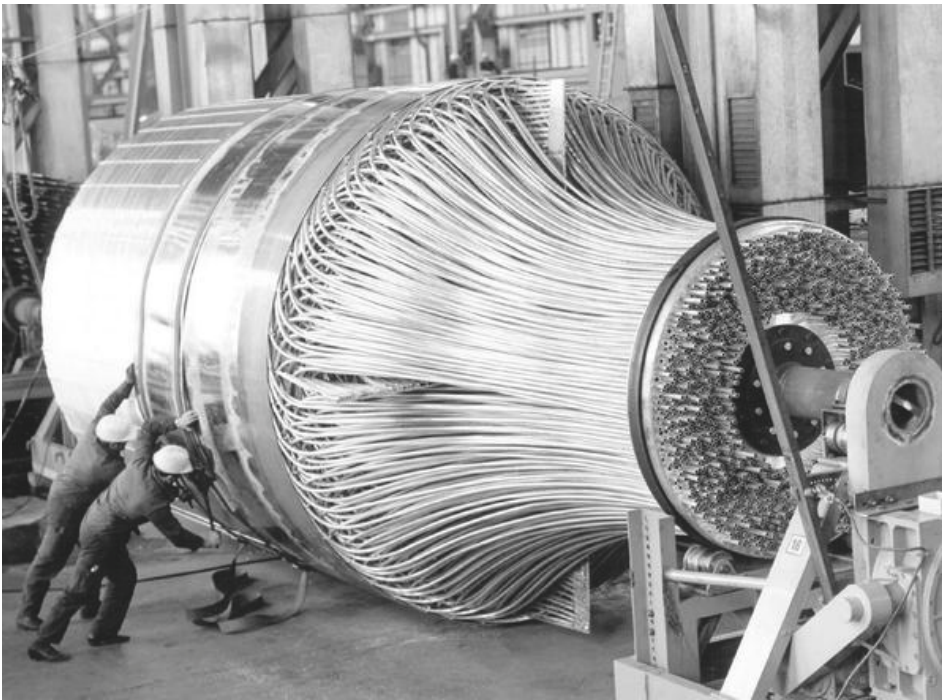

Linde PLC, <https://twitter.com/Lindeplc/status/494838507412938752/photo/1>
RasGas LNG Train 4 Case Study, Ismail & Al Thani, Presented at LNG-18, Perth 2016

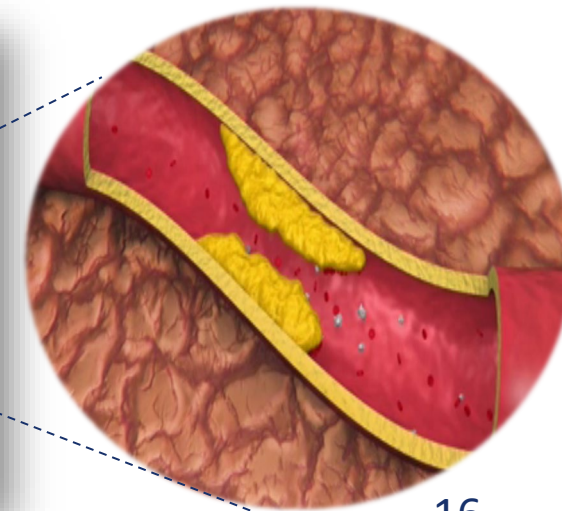
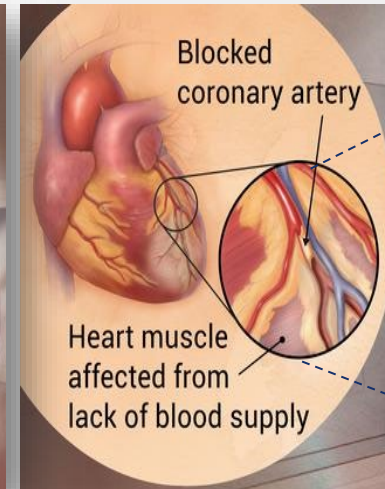
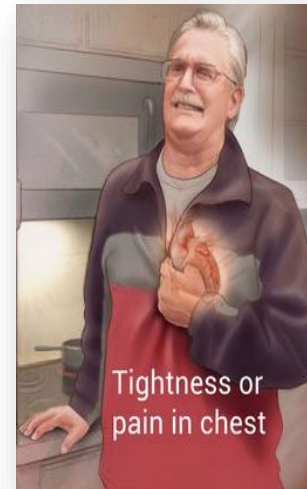

Measuring trace impurity freeze-out in LNG

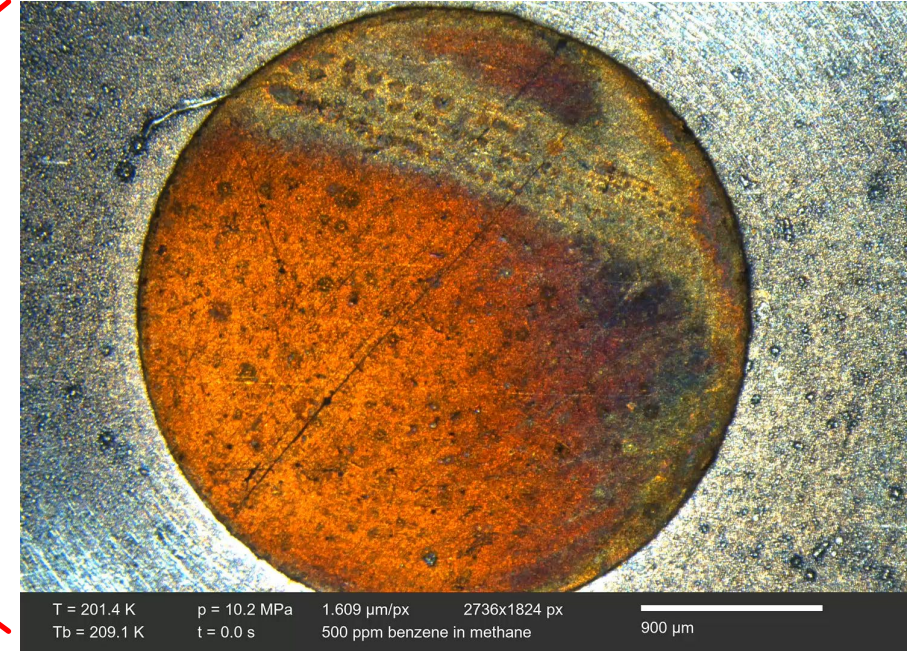
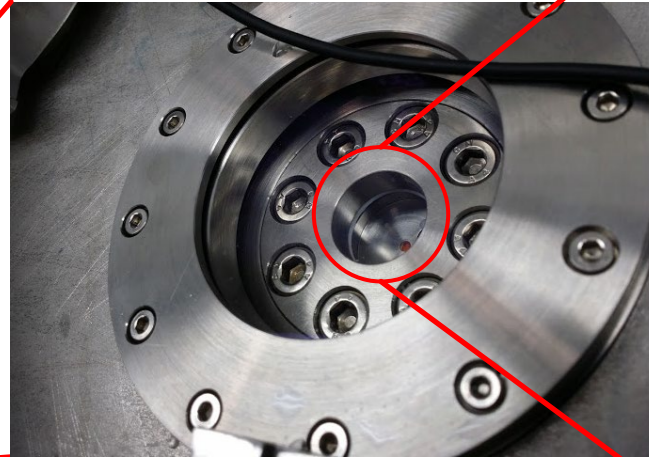
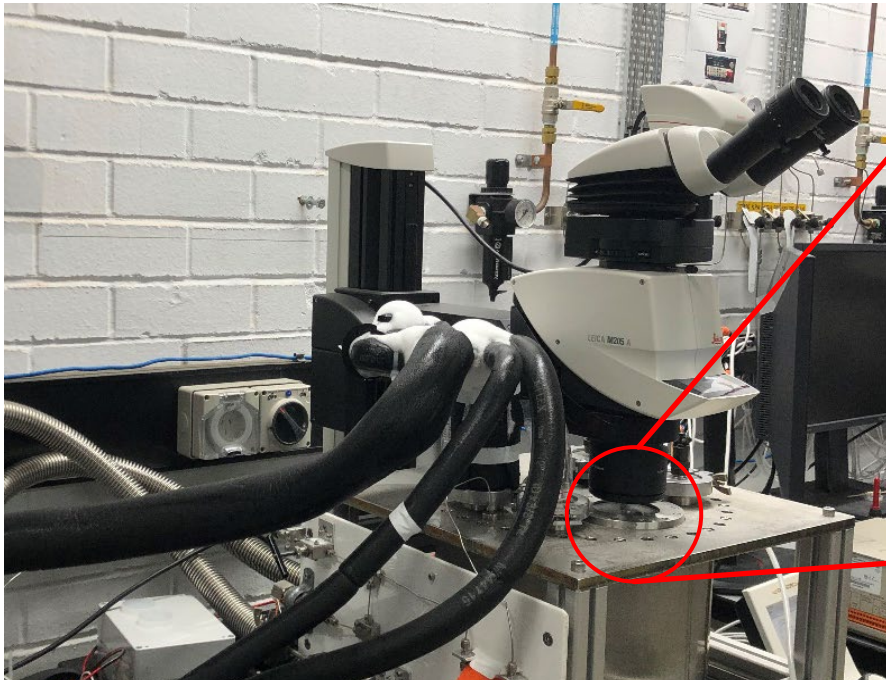

Sampson et al (2020) Chem Eng J
doi:10.1016/j.cej.2020.12708

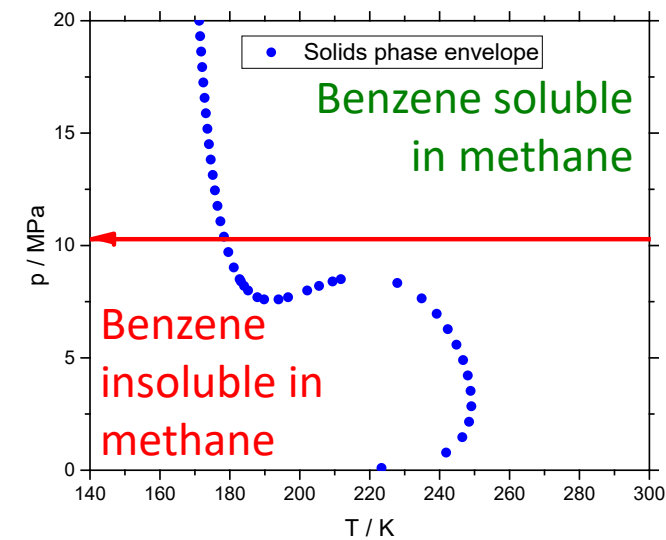
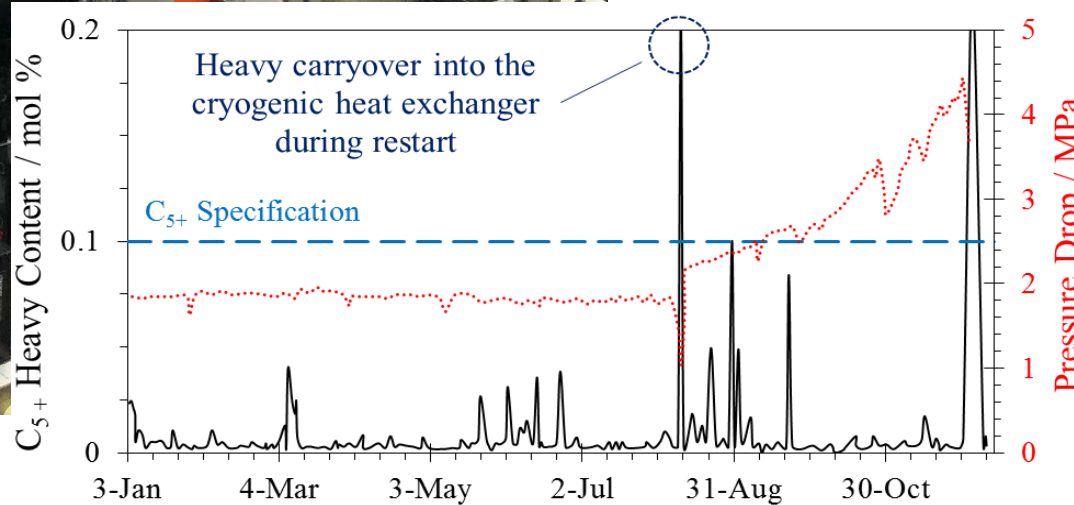

240x speed
Cooling @
2 K/min
Step & hold
T while
stirring to
measure
equilibrium

The Enormous Challenge of Hydrogen Liquefaction

For liquefied hydrogen (LH2) must cool to -253 °C (20 K).

Costs 30% of energy in the H₂!

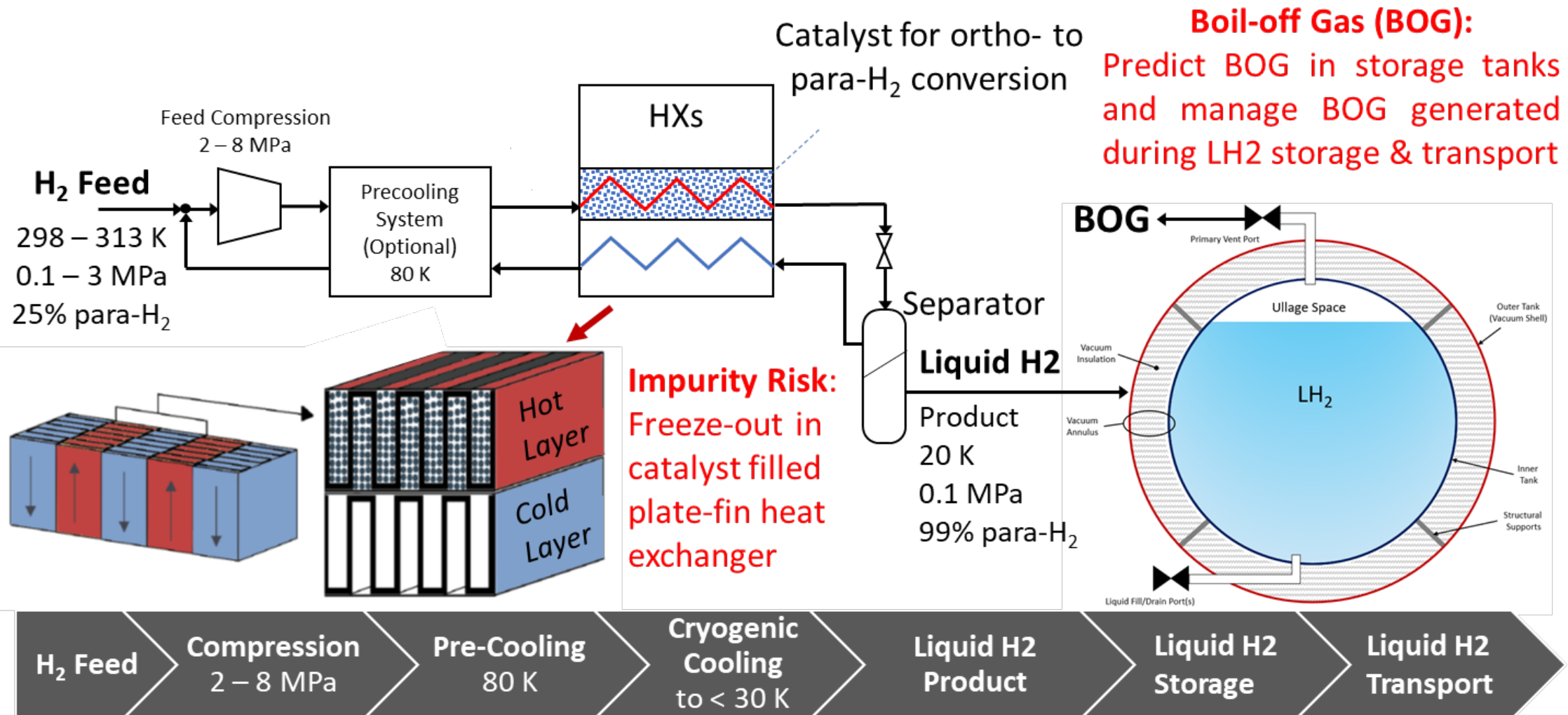

Impurity freeze-out in liquid hydrogen (LH2)

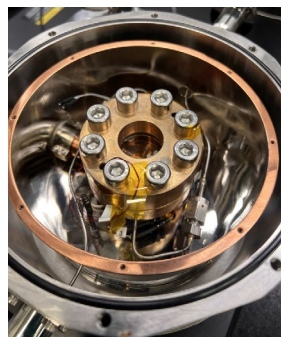
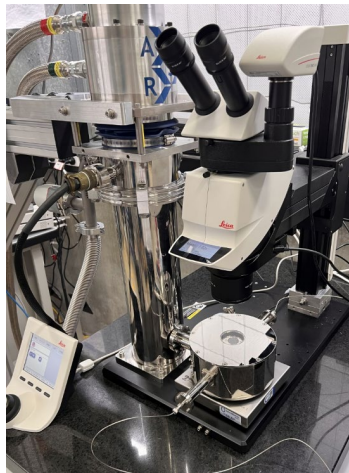
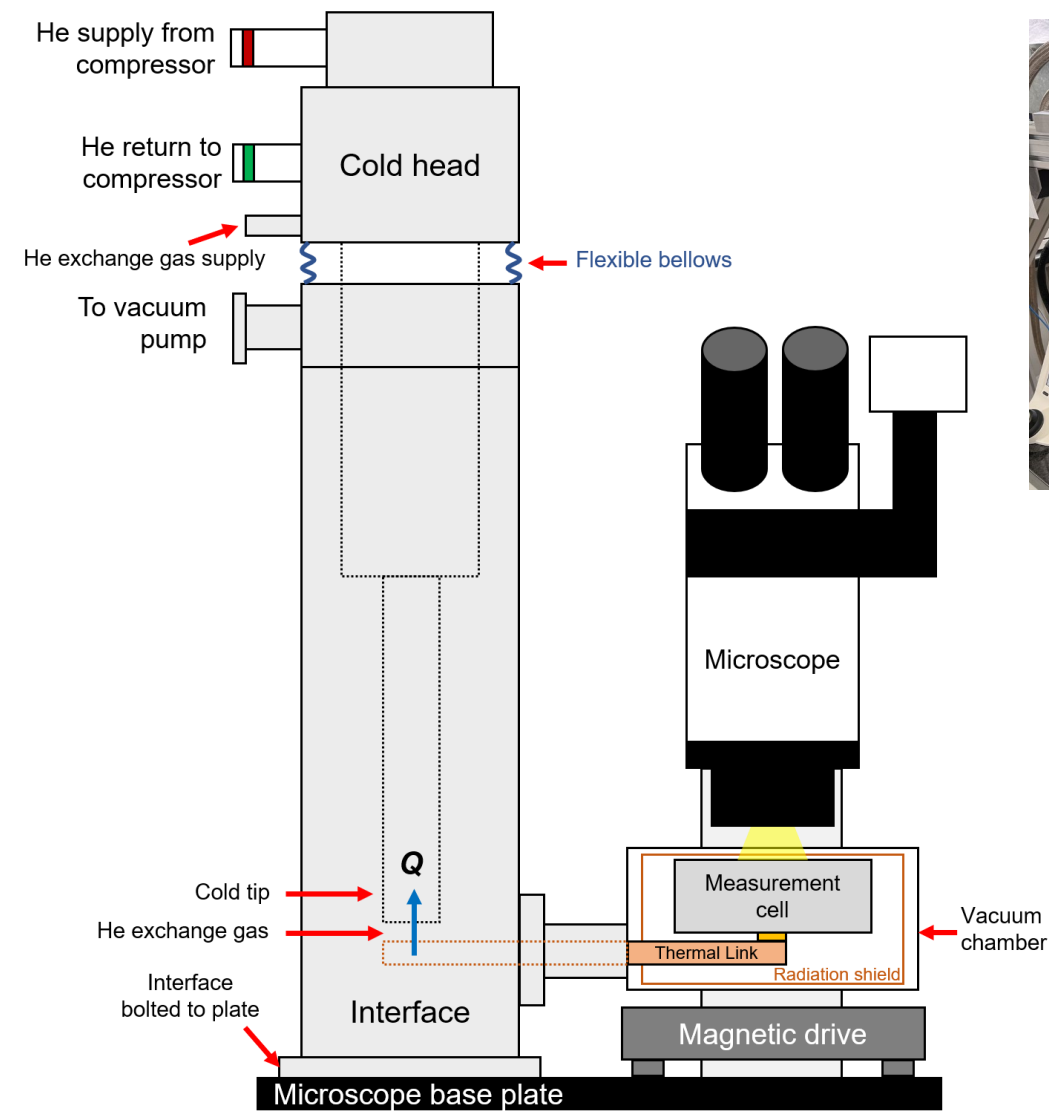

New Cryoscope: Operating conditions
 $p < 10 \text{ MPa}$, $T > 6 \text{ K}$

Literature Data: Solubility of N_2 in H_2

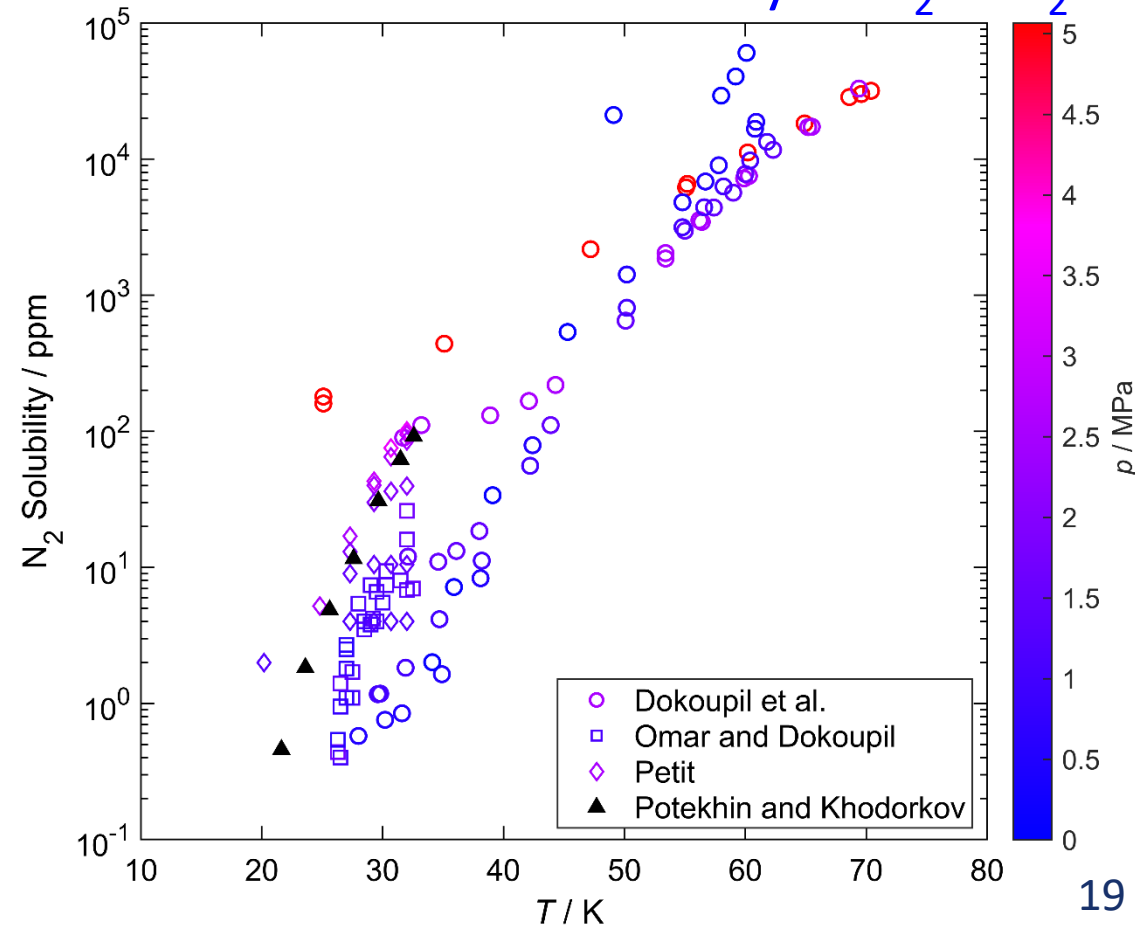

New results for part-per-million (ppm) N_2 solubility in H_2

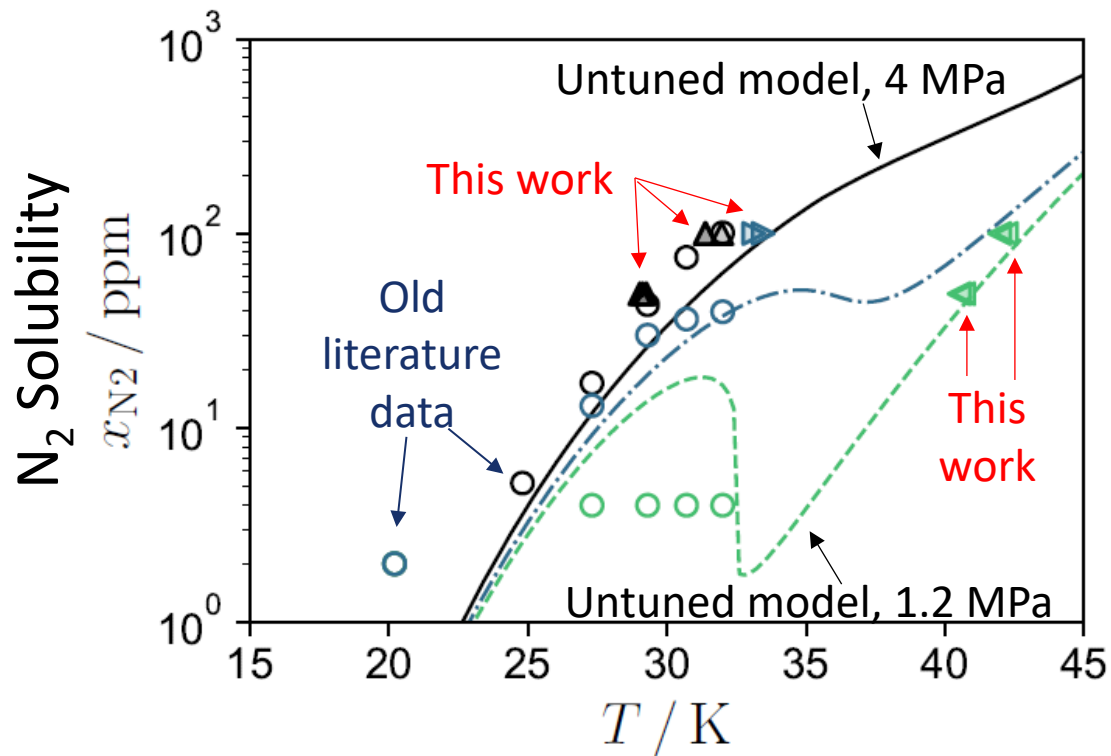
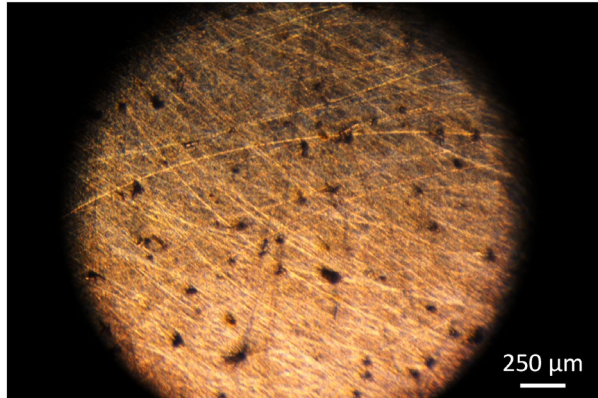

Barwood et al. *Int. J. Hyd. Energy* (2024)

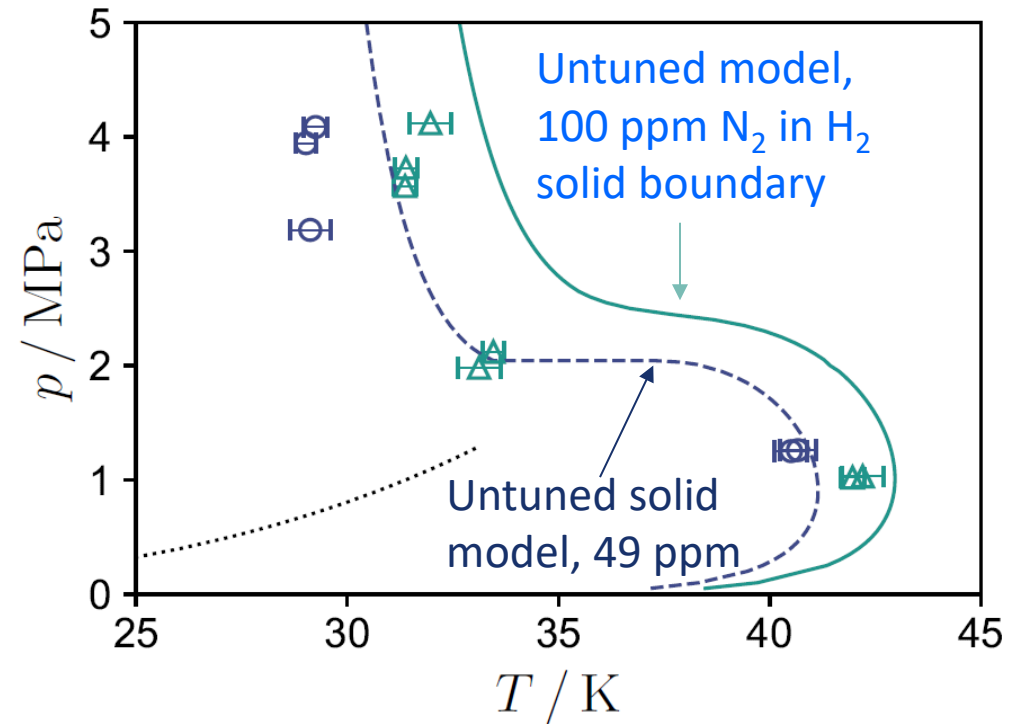

New high-resolution data show N_2 is 10 times less soluble in liquid H_2 than previously thought.

Making LH2 = Industrial Scale Quantum Mechanics

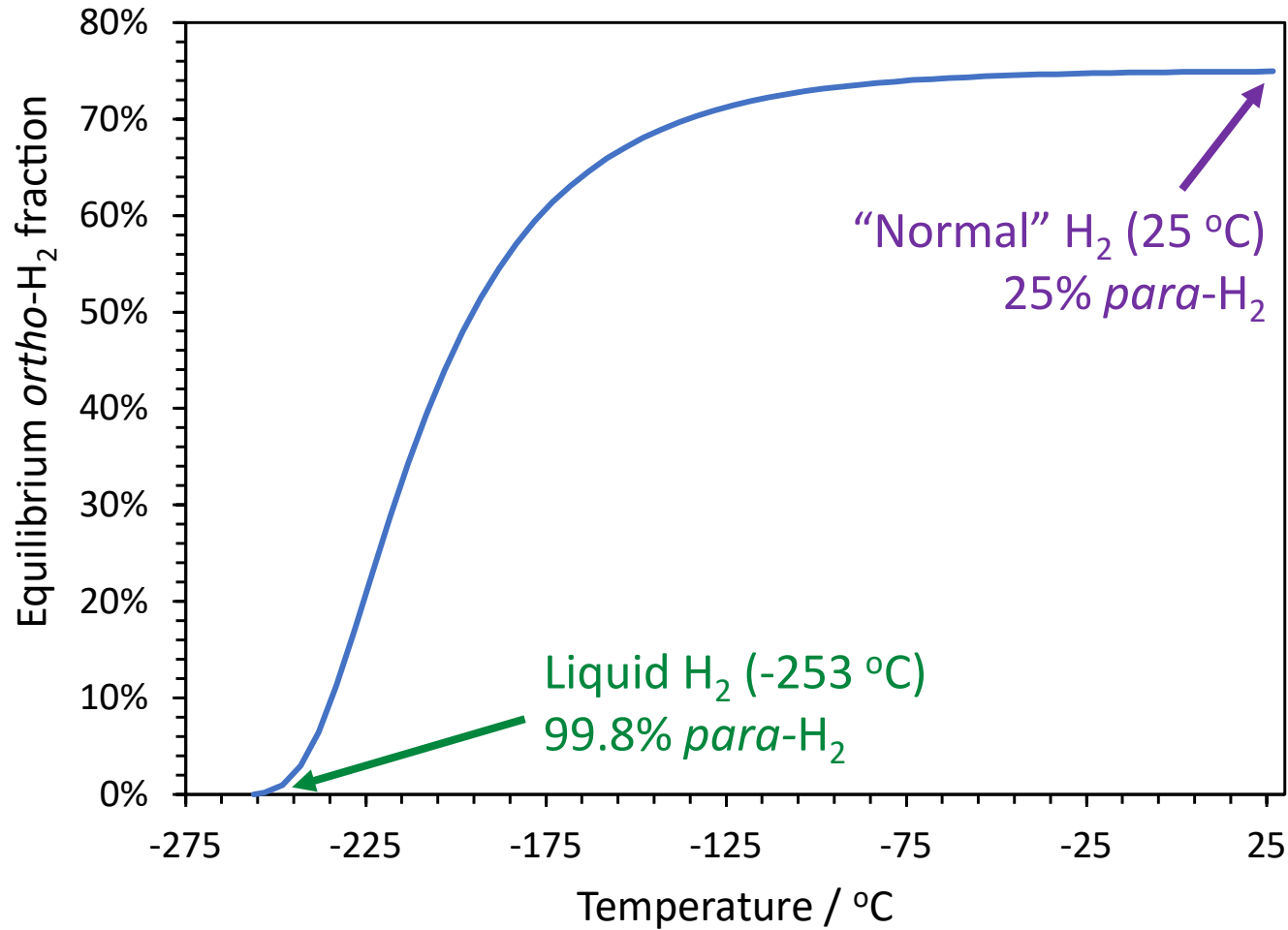

Heat of conversion: 703 J/g

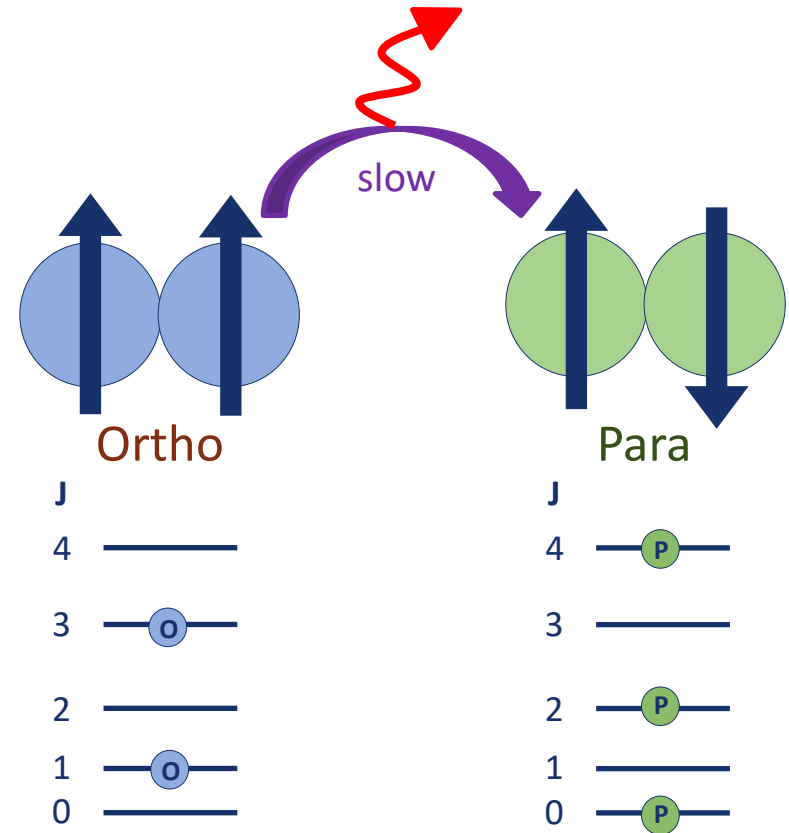

Heat of vaporisation (aka “Boil Off”):
445 J/g

Catalysts Essential for Efficient Hydrogen Liquefaction

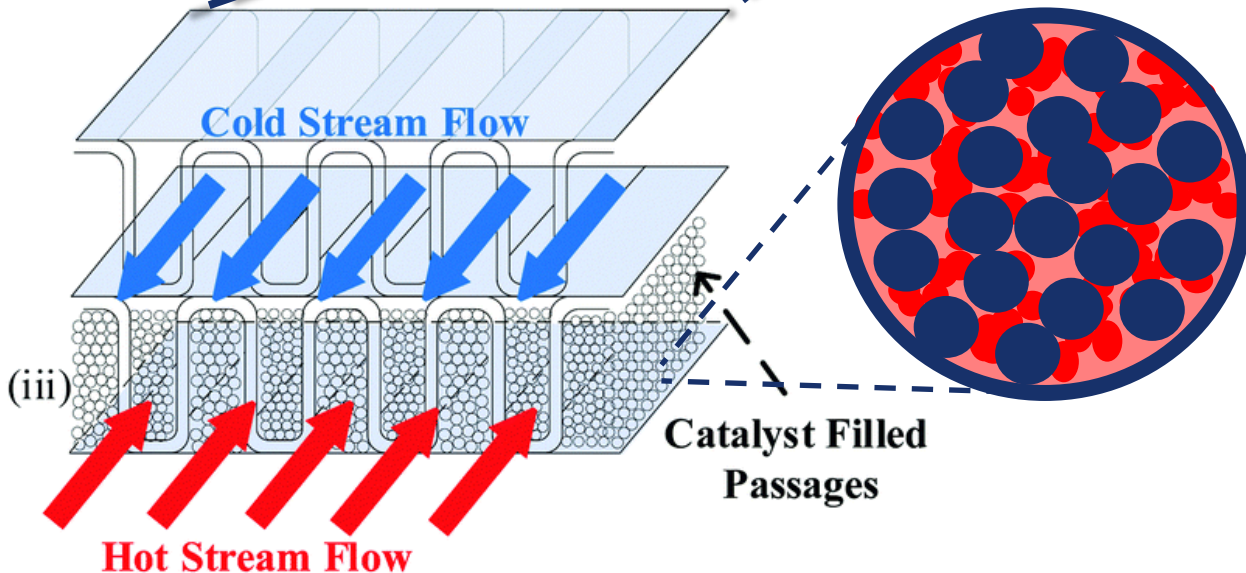
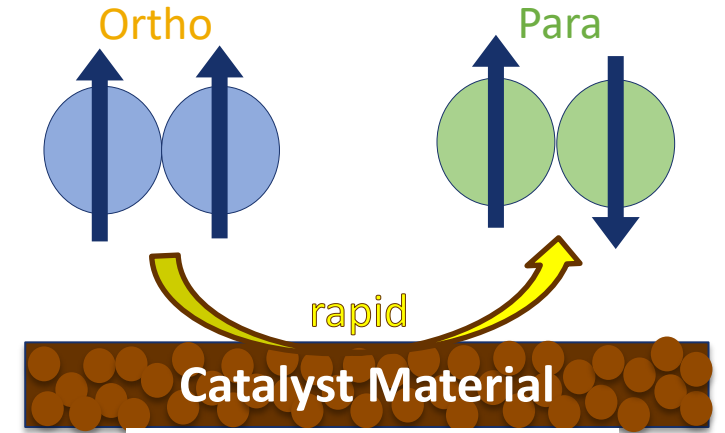
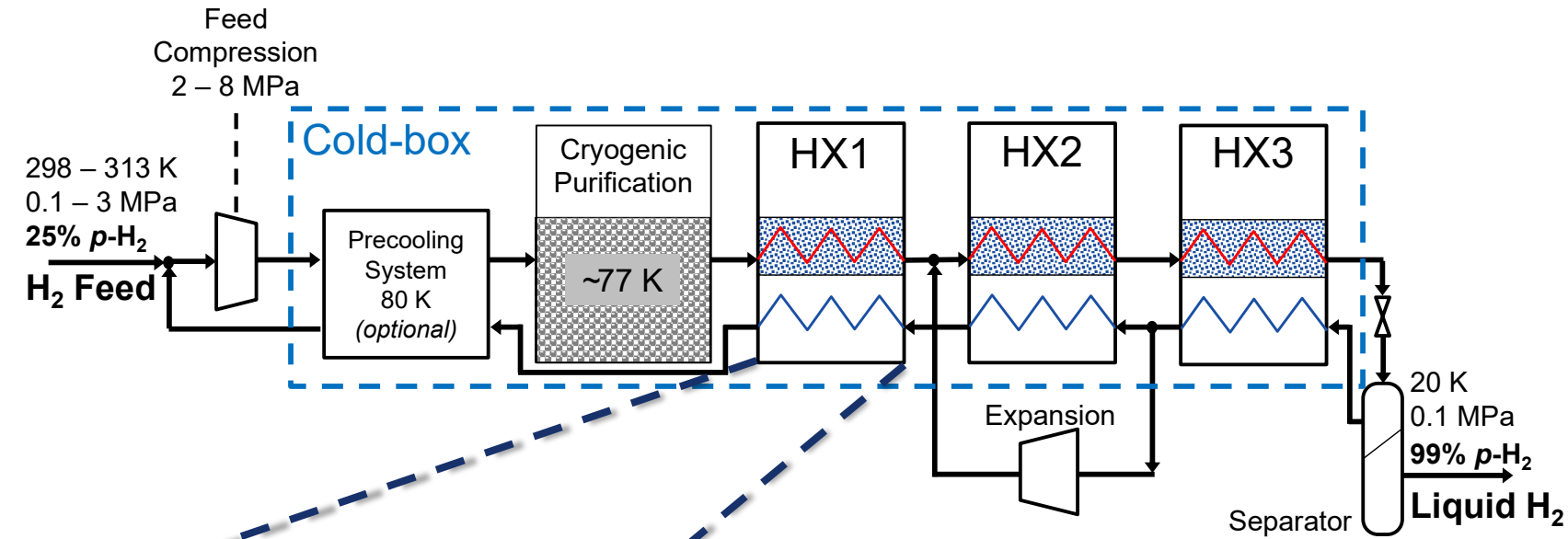

- Catalysts are susceptible to:
- Impurity freeze-out causing blockages
 - **Impurity deactivation** decreasing *ortho-para* conversion rates

Catalytic Conversion of H₂: New sensors and data

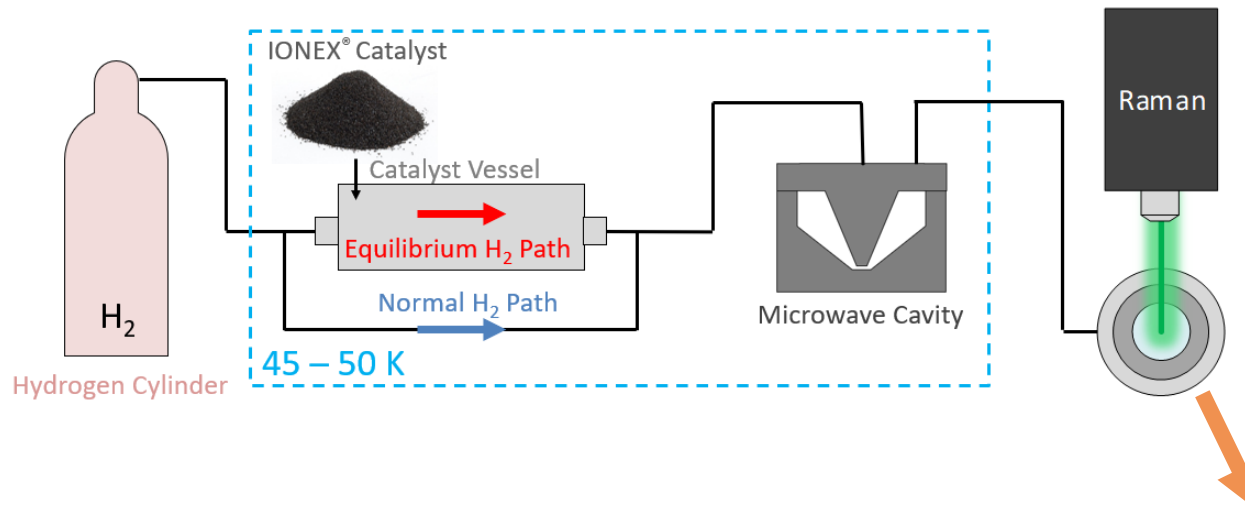

AU2022901016A0
Australia

Find Prior Art Similar

Patent Filed:
14-4-22

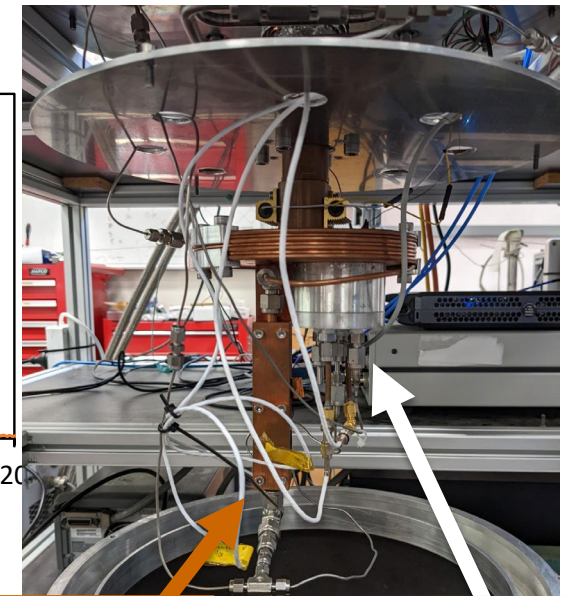
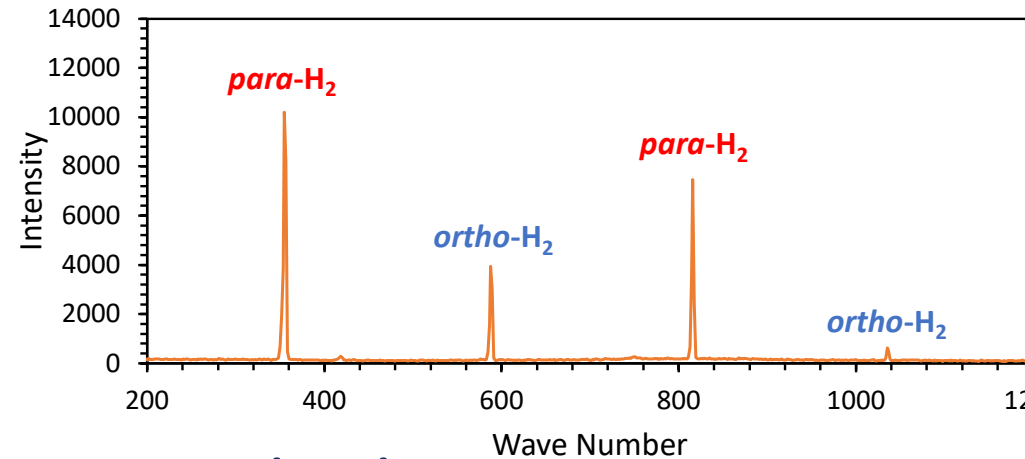
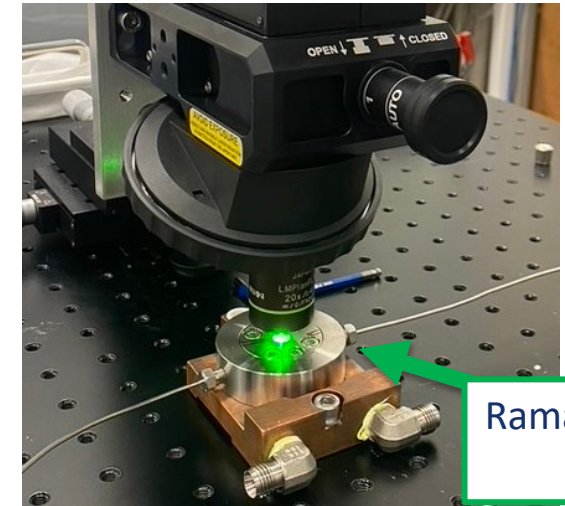

Allows catalyst performance monitoring

- Testing new materials
- Checking for impact of impurities

Ortho-Para Catalyst Activation and De-activation

21 ppmV H₂O Catalyst Deactivation

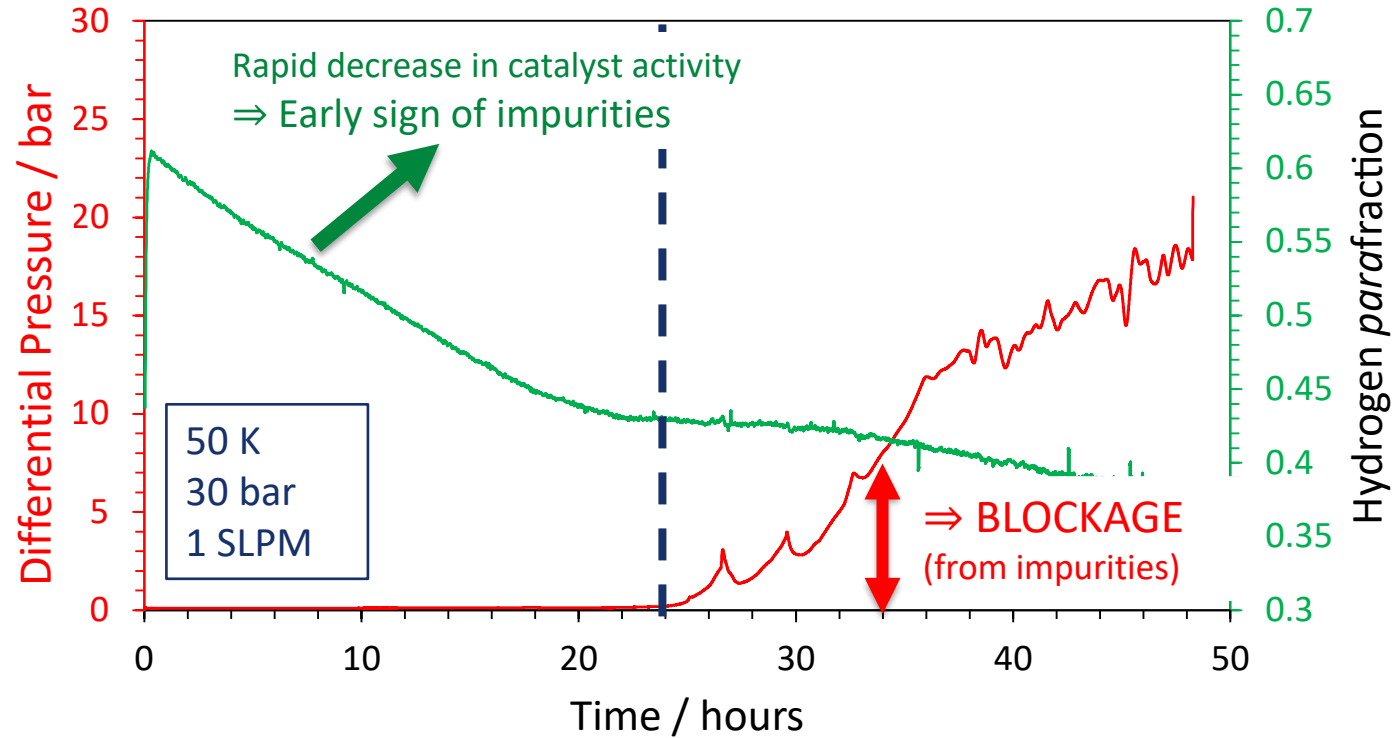

Lowering the cost of hydrogen liquefaction

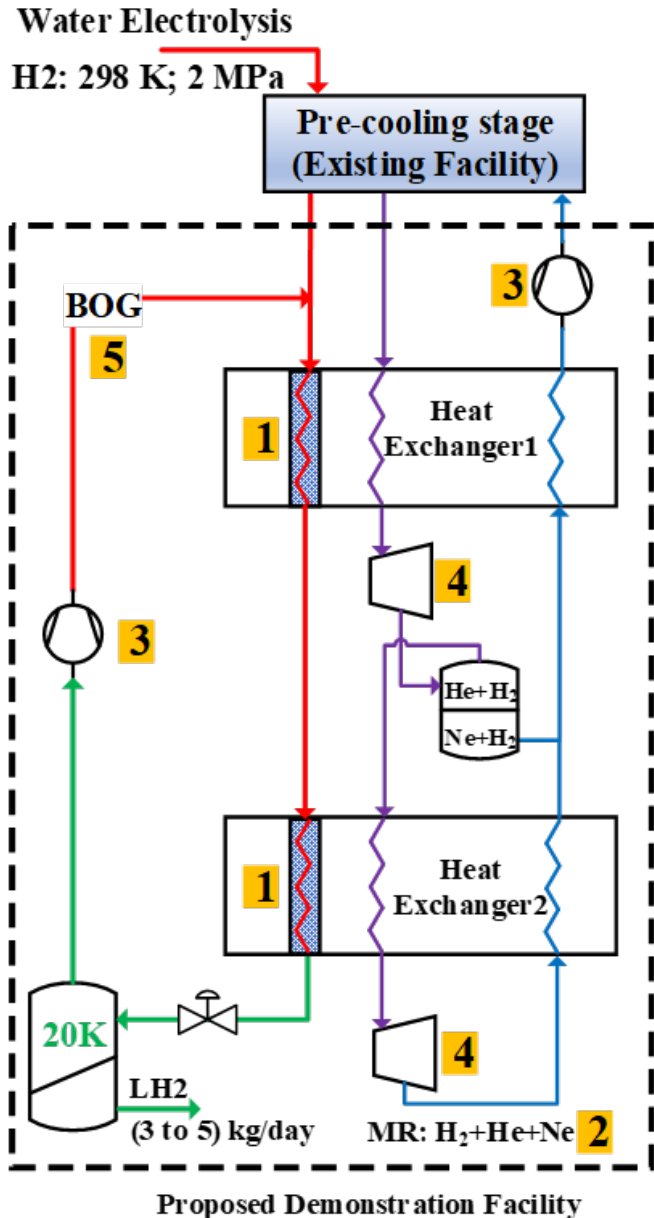

Mixed refrigerant technology widely used in LNG industry to raise liquefaction efficiency

Demonstrate hydrogen liquefier with novel mixed refrigerant technology



Australian Government
Australian Renewable Energy Agency

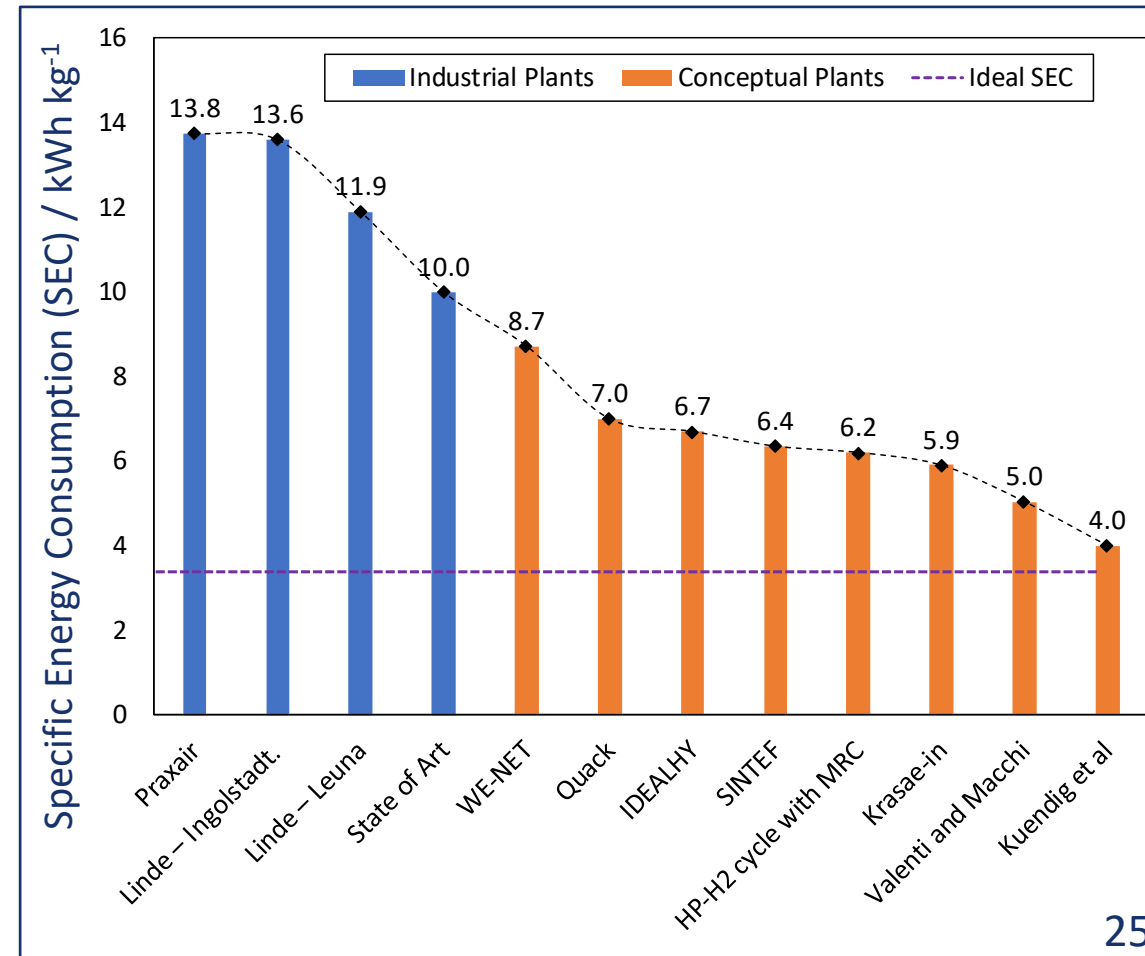

Bringing hydrogen liquefaction research, development & demonstration to Kwinana, Western Australia

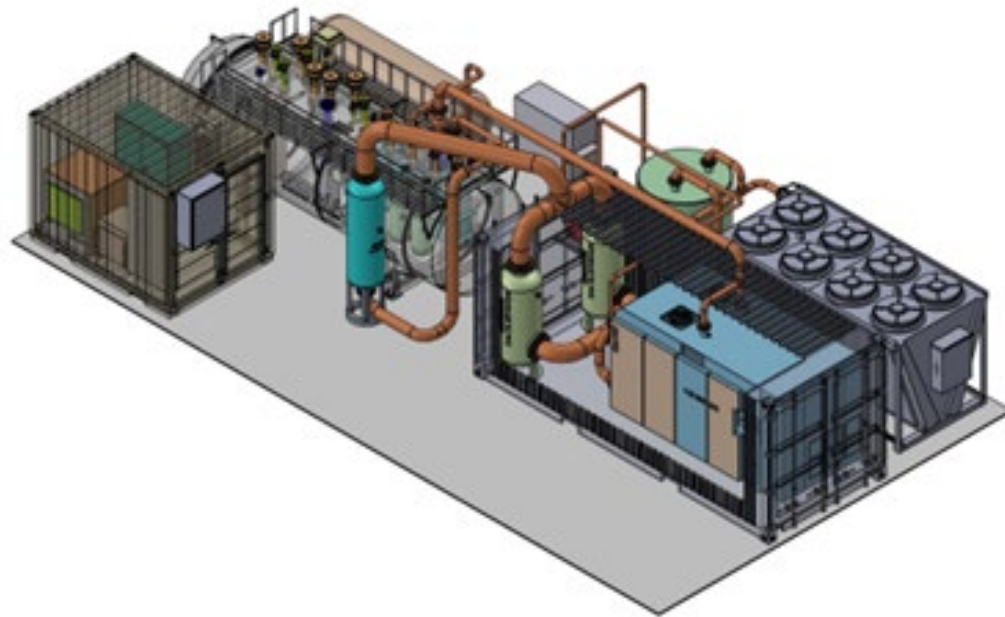

Integrated electrolyser & liquefier at 100 kg/day scale to be demonstrated at FEnEx CRC's Flagship Project - the Kwinana Energy Transformation Hub (KETH)

Conclusions



Future decarbonised energy systems will need to transport H_2 and CO_2

- Moving molecules is cheaper than moving electrons
- No net zero without CO_2 transport



Shipping cryogenic liquids is best way to move molecules overseas

- LNG supply chain is technically mature & cost-efficient



Apply lessons from LNG industry to efficiently transport CO_2 and H_2
Identify differences for CO_2 and H_2 where new knowledge is needed



Research underway to provide solutions

Q & A

Thank you

(c) The University of Melbourne 2025

This material is protected by copyright. Unless indicated otherwise, the University of Melbourne owns the copyright subsisting in the work. Other than for the purposes permitted under the Copyright Act 1968, you are prohibited from downloading, republishing, retransmitting, reproducing or otherwise using any of the materials included in the work as standalone files. Sharing University teaching materials with third-parties, including uploading lecture notes, slides or recordings to websites constitutes academic misconduct and may be subject to penalties. For more information: [Academic Integrity at the University of Melbourne](#)

Requests and enquiries concerning reproduction and rights should be addressed to the University Copyright Office, The University of Melbourne: copyright-office@unimelb.edu.au